



Audi A5 Coupé | A5 Cabriolet | S5 Coupé | S5 Cabriolet

A5 Coupé | Cabriolet

Audi A5 Coupé | Cabriolet

AUDI ME
United Arab Emirates
www.audi-me.com
Valid from April 2014

The models and equipment versions illustrated and described in this brochure and some of the services listed are not available in all countries. Some of the cars illustrated are equipped with optional features for which an extra charge is made. Details concerning the delivery specifications, appearance, performance, dimensions and weights, fuel consumption and running costs of the vehicle were correct to the best of our knowledge at the time of going to press. Deviations from the colours and shapes shown in the illustrations may occur. No liability is accepted for errors and printing errors. The right to introduce modifications is reserved. Not to be reproduced, including in part, without the written approval of AUDI AG.



This brochure is printed on paper made from pulp bleached without the use of chlorine.

Printed in Germany
433/1130.52.26

Vorsprung durch Technik 

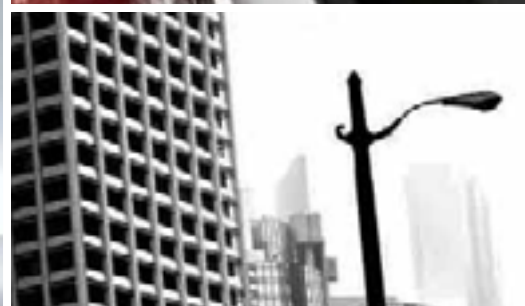

Responsibility

Living up to our responsibilities is a principle that is firmly anchored in Audi strategy. Alongside commercial success and international competitiveness, our responsibility toward company employees and society as a whole is a key consideration, as is protecting the environment and conserving resources. And what is true in the details – our catalogues are printed on FSC-certified paper – also holds in general: Audi develops cars that are not only sporty and emotive but also ever more efficient. In the long run, Audi wants its products

to allow CO₂-neutral mobility. Seeing to it that production in Audi plants gradually becomes CO₂-neutral is another aspect of our comprehensive approach. Audi is also committed to society – particularly in the fields of education, technology and social projects. At Audi, sustainability is closely linked with how we see the future: the Audi Urban Future Initiative sees Audi working with international experts to get to the root of future urban challenges and trends in mobility.

the world of Audi.



Choosing an Audi means choosing a brand that offers more. More individuality. More exclusivity. More fascination.



Team spirit

Motorsport is a driving force behind the brand. For years Audi has been among the champions in various racing series, for instance the 24 Hours of Le Mans or the DTM German Touring Car Masters. The values that are crucial in many different areas of sport are also central ones for Audi: precision, passion and technology. No coincidence then that Audi has been sponsoring sporting events for

many years. In the world of winter sports, for example, Audi has been the main sponsor of the German Ski Association (DSV) for almost three decades and has also partnered 14 other national alpine teams. In football, we support national and international teams. And Audi is also a partner for the German Olympic Sports Confederation.

www.audi-me.com

Information on all the topics mentioned above can be found on our website: www.audi-me.com.

 www.audi-me.com

 www.audi-me.com/driving

 configurator.audi-me.com

 www.audi-me.com/vorsprung-durch-technik

Equipment Audi A5 Coupé/A5 Cabriolet			
Hood linings	94	S line competition	56, 57
Ignition lock	99	S sport seats, front	69
Inlays	74, 75	S tronic®	86
Instrument cluster	100	Safety steering column	101
Integrated head restraint system	87	Seat belts	101
Interior lighting	98	Seat heating systems	71
Interior mirrors	78	Selector lever knob in leather	99
ISOFIX child seat mounting	87	Ski/snowboard bag	80
Lashing points	80	Sockets	81
Leather upholstery and trim	72, 73	Spare wheel, space-saving	96
Leather-covered door trim armrests	72	sport seats, front	69
LED rear lights	76	Standard seats, front	68
Light/rain sensor	76	Start-stop system	86
Lighting package	76	Steering wheel rims	78
Luggage compartment lid, automatically opening	80	Steering wheels	77
Luggage compartment package	80	Storage compartments	80
Misfuelling protection	101	Storage package	80
MMI® navigation	81	Style guides	50, 51
MMI® navigation plus	81	Sun visors	99
multitronic®	86	Sunblind, electric for the rear window	79
Paint finishes	64, 65	Suspensions	85
Panoramic tilt sunroof	78	Through-loading facility with removable ski/snowboard bag	80
Parking systems	84	Trailer towing hitch	81
Preparation for mobile phone (Bluetooth)	83	Tyre pressure loss indicator	96
Preparation for tracking system	80	Tyre repair kit	96
Provision for trailer towing hitch quattro®	81	Vehicle jack	96
quattro®	86	Vehicle tool kit	96
quattro® with sport differential	86	Warning triangle	101
Radios	82	Wheels/tyres	66, 67
Rear lights	76	Wind deflector	79
Rear seat backrest, folding	71	Windscreen cleaning system	99
Recuperation	86	Xenon plus including headlight cleaning system	76
Remote control key	80		
S line	54, 55		

Equipment Audi A5 Coupé/A5 Cabriolet			
3-zone deluxe automatic air conditioning	79	Climate-controlled comfort seats, front	70
4-way lumbar support for the front seats	71	Cloth upholstery and trim	72
6-speed manual transmission	101	Convenience key	80
Acoustic hood	78	Cruise control	84
Active roll-over protection	101	Cup holders	80
Adapter cable sets for Audi music interface	82	Dark-tinted windows (privacy glazing)	79
adaptive cruise control	85	Digital Audio Broadcasting	82
adaptive light	76	Digital TV reception	82
Airbags	76	Door sill trims	77
Aluminium-look exterior	77	Driver information systems	81
Aluminium-look interior	77	Dynamic steering	86
Anti-Slip Regulation (ASR)	86	Electromechanical parking brake	86
Anti-theft alarm	80	Electromechanical power steering	86
Anti-theft wheel bolts	96	Electronic Differential Lock (EDL)	86
Antilock Brake System (ABS) with Electronic Brake Force Distribution (EBD)	101	Electronic immobiliser	99
Assistance package	85	Electronic Stabilisation Control (ESC)	86
Attention assist	100	Electronic Stabilisation Control (ESC) with electronic axle-differential lock	86
Audi active lane assist	85	Exhaust tailpipes	77
Audi connect including car phone	83	Exterior mirrors	78
Audi design selection	58, 59	First-aid kit	101
Audi drive select	85	Floor mats	77
Audi exclusive	62, 63	Front fog lights	76
Audi exclusive aluminium gear lever knob	78	Front seats, electrically adjustable	71
Audi exclusive carpet and floor mats	77	Front-wheel drive	101
Audi exclusive leather controls	78	Garage door opener (HomeLink)	80
Audi exclusive line	60, 61	Gloss packages	77
Audi Genuine Accessories	88, 89	Glove compartment	80
Audi music interface	82	Grab handles	96
Audi side assist	85	Handset in the front for car phone	84
Audi sound system	83	Headlights	76
Automatic air conditioning	79	Head restraints	96
Automatic seat belt presenter	101	Headlinings	98
Auxiliary heating/ventilation	79	Headroom heating	71
Bang & Olufsen Sound System	83	Heat protection	71
Bluetooth car phone	84	Heat-insulating glass	99
Bluetooth interface	83	High-beam assist	76
Brake system	86	Hold assist	84
CD changer	83	Hood	79
Cigarette lighter and ashtrays	80	Hood colours	64
		Hood compartment, variable	100

Page			
Fascination			
<hr/>			
	4	Audi A5 Coupé	20
Technology			
<hr/>			
	32	Innovations	40
	34	Audi ultra	42
	36	Audi connect	44
	38	quattro®	46
Equipment			
<hr/>			
	50	Style guides	74
	52	Engines	76
	54	S line	77
	58	Audi design selection	77
	60	Audi exclusive line	78
	62	Audi exclusive	81
	64	Paint finishes/hoods	84
	66	Wheels/tyres	85
	68	Seats	
Other			
<hr/>			
	88	Audi Genuine Accessories	94
	90	Technical data	102
	93	Dimensions	

Dialogue: Audi QR codes

Experience Audi even more directly: download a QR app to your smartphone and then scan the QR code or follow the given link provided in your browser.



The equipment for the vehicles illustrated in the Fascination section can be found on page 101.

The fuel consumption and CO₂ emission figures as well as the efficiency classes can be found from page 90 onwards.



The first coupé shaped by determination.

There is nothing more exciting than a première. Especially in your new car. The first sight of it. The first time you accelerate, the first corner, the first long ride. For this special feeling, there is a very special car: the Audi A5 Coupé. In an elegant design, with even greater driving dynamics. For new ways, new thoughts, new ideas. Get in. And experience every ride like it was your first.

The fuel consumption and CO₂ emission figures as well as the efficiency classes can be found from page 90 onwards.

A5

Audi A5 Coupé



The Audi A5 Coupé plays with the proportions of classic coupés. The flat roof and the sweep of the roof line convey a sporty elegance. A multitude of rich colours and attractive tyre/wheel combinations between 17 and 20 inches in size emphasises the design.

The fuel consumption and CO₂ emission figures as well as the efficiency classes can be found from page 90 onwards.



The precise downward sloping lines of the expressive front and the three-dimensionally carved out bonnet symbolise determination and give the A5 Coupé a convincing stance. The sculptural transverse braces of the Singleframe are impressive and underline the three-dimensional design. The optional xenon plus headlights also have a striking LED daytime running light strip. The front fog lights are integrated into the high-gloss blade. The rear lights elegantly combine the side with the rear; the shoulder line passes through them and ends in a clear bumper edge.

The fuel consumption and CO₂ emission figures as well as the efficiency classes can be found from page 90 onwards.



The A5 Coupé not only looks sporty – the dynamism of its inner values are also very convincing. The quattro permanent all-wheel drive with wheel-selective torque distribution and self-locking centre differential will help you stay on track better. On request, quattro is also available with sport differential.

The A5 Coupé is extremely efficient: the highly supercharged injection engines are among the most economic and cleanest currently available worldwide. All engines are equipped with the start-stop system and recuperation as standard.

The standard electromechanical power steering works depending on the speed and ensures greater steering precision and comfort. In addition, it only uses fuel if you actively request power steering assistance.

The fuel consumption and CO₂ emission figures as well as the efficiency classes can be found from page 90 onwards.





Numerous innovative and advanced assistance systems increase both safety and comfort. For example, Audi active lane assist warns you if you inadvertently drift out of your lane, while adaptive cruise control regulates the distance to the vehicle in front – even bringing you to a complete standstill under certain circumstances. Audi drive select lets you drive according to your mood – comfortably or sportily as you prefer. On request, the dynamic steering option can be ordered with the system: this adapts to the selected mode and ensures smoother running or faster implementation of your steering commands.





The interior radiates elegance and sportiness. The architecture is harmonious and creates a lively atmosphere. Selected materials emphasise the high quality of workmanship, which you will see and above all feel. The standard sport leather steering wheel in 3-spoke design provides good grip, as does the ergonomically shaped gear or selector lever knob, which is also leather-covered.

The optional MMI navigation plus is intuitively operated via the MMI rotary/push-button control with integrated joystick. MMI navigation plus features include a high-quality 7-inch colour display, 3D map representation and a hard drive for your personal music and media files.

On request, you even have numerous services supported by Audi connect at your disposal in conjunction with Audi connect including car phone. These include the vehicle's own Wi-Fi hotspot, navigation with the aid of Google Earth™* and Google Street View™* or traffic information online, for example. More information about these features can be found on page 36 under Audi connect.

*Google and the Google logo are registered trademarks of Google Inc.



No matter what you plan to do in your Audi A5 Coupé – you will enjoy every second. Thanks, for example, to comfortable seats covered with whatever material you wish: exclusive cloth trim, finest-grade leather or a combination of high-quality Alcantara and leather. On request, you can also choose the ventilated and heated climate-controlled comfort seats in the front. The generous proportions of the optional electric panoramic tilt sunroof with sunblind make the journey even more pleasant for all the occupants.

The fuel consumption and CO₂ emission figures as well as the efficiency classes can be found from page 90 onwards.



More experience: a new driving sensation.

There are moments you have already experienced lots of times. But all of a sudden, they feel new again. Because all at once everything feels more intense. Because you feel more and experience more than usual.

A ride in the Audi A5 Cabriolet is one of those moments. Because you exchange what you are used to for something unusual. And you feel that it is more than just a Cabriolet. It is a new driving sensation.

The fuel consumption and CO₂ emission figures as well as the efficiency classes can be found from page 91 onwards.

A5

Audi A5 Cabriolet



The first exciting journey is made by your eyes. The moment they take in the silhouette of the Audi A5 Cabriolet. Its long wheelbase. The extended bonnet. The short overhangs. Details which underline the athletic Coupé character just as much as the striking body lines do.

An unmistakable presence with the fully automatic fabric hood: it is characterised by a high degree of comfort and well thought out details when both open and closed. So it only takes 15 seconds for it to let the summer freshness in. Up to a speed of 50 km/h the hood can be operated while driving. Only the optional acoustic hood is even more impressive. When closed, it reduces noise so effectively that you can fully concentrate on your driving experience.

The fuel consumption and CO₂ emission figures as well as the efficiency classes can be found from page 91 onwards.



With the extremely efficient TFSI engines in the Audi A5 Cabriolet you will soon forget your everyday affairs and get on with discovering something new. Enormous torque strength and power reserves characterise the engines just as smooth running and efficiency. Bundled engineering power is embedded in each of the engines.

When cornering, you feel the athletic character particularly clearly. One of the factors responsible for this is the optional quattro all-wheel drive with wheel-selective torque distribution and self-locking centre differential which variably distributes driving force. The electromechanical power steering assists you with high dynamics in curves and stability on the straight.

The fuel consumption and CO₂ emission figures as well as the efficiency classes can be found from page 91 onwards.



The optional xenon plus headlights with LED daytime running light strip give the Audi A5 Cabriolet a determined look. The striking front section and the layout of the horizontal lines on the rear enhance this impression. Exclusivity does not fall by the wayside: accentuated high-gloss elements highlight the individuality and turn each stop into sheer enjoyment.

The fuel consumption and CO₂ emission figures as well as the efficiency classes can be found from page 91 onwards.



It is the intense driving moments which make the Audi A5 Cabriolet so inviting and these moments are expressed in the interior. At a glance you are aware of the tremendous attention to exclusivity, design and technology. And to your comfort: on request, heated and ventilated climate-controlled comfort seats as well as headroom heating at the front make for a relaxed journey. The automatic seat belt presenter and the optional cup holders integrated in the rear bench seat make the journey even more pleasant.

The fuel consumption and CO₂ emission figures as well as the efficiency classes can be found from page 91 onwards.



Top-quality materials create an exclusive atmosphere and emphasise the high-quality craftsmanship. Each detail is ergonomically tailored to the driver – like the optional MMI navigation plus, for example. You can navigate using the high-resolution colour display and the aid of 3D map representation – or even with Google Earth™* and Google Street View™* in conjunction with Audi connect including car phone. At the same time, you can use the integrated hard drive for your music and video files. Just in case you want to enjoy more than the wind in your hair and the countryside.

*Google and the Google logo are registered trademarks of Google Inc.



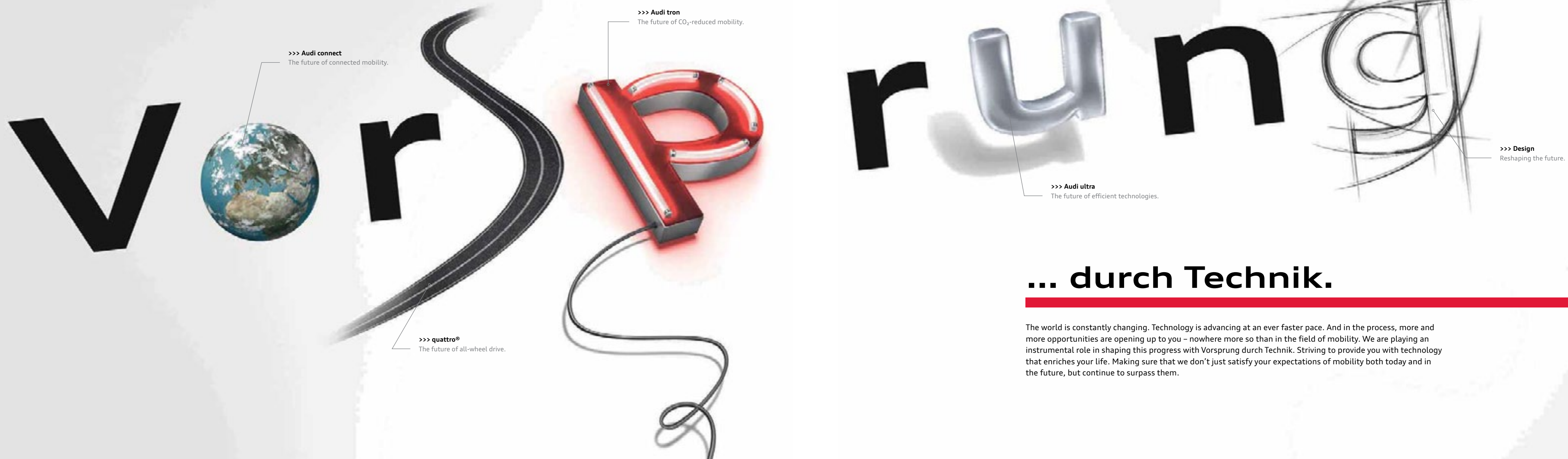

>>> **Audi connect**
The future of connected mobility.

>>> **Audi tron**
The future of CO₂-reduced mobility.

>>> **quattro®**
The future of all-wheel drive.

>>> **Audi ultra**
The future of efficient technologies.

>>> **Design**
Reshaping the future.

... durch Technik.

The world is constantly changing. Technology is advancing at an ever faster pace. And in the process, more and more opportunities are opening up to you – nowhere more so than in the field of mobility. We are playing an instrumental role in shaping this progress with Vorsprung durch Technik. Striving to provide you with technology that enriches your life. Making sure that we don't just satisfy your expectations of mobility both today and in the future, but continue to surpass them.

Audi ultra

Perfectly combined.

The future of efficient technologies.

Building an Audi is an extremely complicated business. And yet a simple principle applies for all models: all vehicle components interlock precisely in order to produce emission-reducing synergies. What started in accordance with this principle at the end of the 1980s with Audi lightweight construction and the revolutionary Audi Space Frame (ASF®) is now known as the reversal of the weight spiral: every lightweight component has an impact on other components, which can in turn be made smaller. In this way, existing forms and materials are continuously being improved with regard to their functionality, the lowest possible weight and their production process. With the goal of building vehicles that are even more efficient and make more sparing use of resources. At the same time, more and more efficiency technologies are being built into an Audi. These include recuperation and the start-stop system. Not to mention progressive, efficient high-tech engines. For greater driving dynamics, high compression, more efficient combustion and lower CO₂ emissions. All this is known as Audi ultra. Today and in the future – towards CO₂-reduced mobility.

>>> Aerodynamics

Less drag, more efficiency. Thanks to the consistently aerodynamic styling of the vehicle's lines, its underbody and spoiler edges – in order to achieve the best possible shape for aerodynamic efficiency. Not forgetting tyres with reduced rolling resistance. All tested in the Audi wind tunnel at up to 300 km/h.

>>> Lightweight expertise

Less weight. More savings, power and endurance. Audi lightweight technology. What started in lightweight body construction has now made its way into nearly all areas, combining innovative materials such as aluminium, carbon and magnesium, intelligent design principles and resource-saving manufacturing processes into an overall concept.

>>> Transmission expertise

Improved efficiency thanks to improved transmission ratios. A higher torque output makes longer ratios possible, especially in higher gears. For powerful torque in the low engine speed range, which reduces consumption – yet has no adverse effects on driving performance and sportiness.

>>> Recuperation

Braking that leads to even more efficient driving. With brake energy recovery (recuperation). Part of the kinetic energy produced when braking and coasting is temporarily stored in the vehicle's battery and then used when accelerating. Depending on the driving cycle, this can save up to 3% of fuel.

>>> Engine expertise

Powerfully and efficiently driven. By Audi ultra with efficiency technologies in the engine sector. Such as Audi cylinder on demand and the Audi valvelift system, which both reduce the amount of energy consumed by the engine, or clean diesel technology, which can help to reduce emissions.

Mobility & navigation

POI **Point-of-interest (POI) search for A5 Coupé additionally with voice control** in the Google™ database

Traffic information online complements the dynamic route guidance with real-time traffic flow information for individual stretches of road

Fuel prices the cheapest petrol stations at your destination or in the vicinity

P **Parking information** Help with looking for car parks and multi-storeys, plus – where available – information on prices and currently vacant spaces

Country information The legal regulations for a specific country, such as speed limits or whether it is compulsory to carry a high-visibility vest, can be called up at any time in the MMI at the push of a button.

Navigation with Google Earth™ and Google Street View™ uses high-resolution aerial and satellite images, photos and address information to guide you to your destination even more easily

myAudi **Destination entry via myAudi or Google Maps™** If you want, you can plan your navigation destinations from your home computer. myAudi and Google Maps™ allow individual navigation destinations to be sent to the vehicle. When you start your journey, these can easily be loaded as your destination.

Communication

Wi-Fi hotspot connects your mobile devices to the internet



If you want to experience the full diversity of Audi connect, scan this QR code using your smartphone. Or follow this link in your browser: www.audi.com/audiconnecta5

myAudi – your personal control centre provides you with password-protected access to www.audi.com/myaudi where, following one-off registration, you are able to manage the services supported by Audi connect and configure them from the comfort of your own home

* Google and the Google logo are registered trademarks of Google Inc.

Availability, screen display and the cost of services vary depending on the country, model, device and tariff. For further legal information and notes on use, please see page 83 or visit www.audi.com/connect. The fuel consumption and CO₂ emission figures as well as the efficiency classes can be found from page 90 onwards.

Audi connect.

Audi connect

The future of connected mobility.

The world presents you with countless possibilities. Audi connect enables you to make the most of many of them in digital form directly from your Audi A5. At the push of a button. Tailored to you. Thanks to myAudi and the services supported by Audi connect in your Audi A5. In places all over the world. Intuitively, easily and conveniently.

Infotainment

Weather forecasts and maps for the required destination

Audi music stream access to global radio stations via smartphone app and Wi-Fi, plus access to your smartphone's media library

NEWS **News online** text and images about current world events

City events up-to-date information about events – e.g. at your destination

i **Travel information** sightseeing information – with a function for importing the destination to the navigation system

Have the road completely under control, thanks to permanent distribution of the drive force to all four wheels. Variably controlled by the centre differential. Always depending on the situation. Experience handling stability, dynamism and agility as never before and combat the effects of over- and understeer with quattro with optional sport differential. For increased traction and superior propulsive power. Tame any road. And always keep your eyes set on where you're heading. In bends. On straights. Over any surface. For a fascinating experience that sticks. To the road – and in your mind.



quattro®
**Stick to
the road.**

With quattro®.

Maximum power. Put to maximum use.

Every movement originates from something. Something that sets it off, an idea. The engine in your Audi A5 can also be traced back to an initial spark of inspiration: higher power with lower fuel consumption. These apparently conflicting aims are united in the revolutionary TFSI drive technologies. Get acquainted with both of them. And then opt for the drive system that you feel most moved by.



The fuel consumption and CO₂ emission figures as well as the efficiency classes can be found from page 90 onwards.



TFSI®

Audi TFSI engines attain a particularly high compression rate. The result: outstanding efficiency combined with optimum performance. Substituting supercharging for cubic capacity has the effect of considerably reducing engine size and weight – while performance remains as impressively dynamic as ever. For power delivery that will win you over from the word go.

>>> S tronic®

The sporty, efficient dual-clutch transmission allows you to switch gears with lightning speed with virtually no break in propulsive power.

>>> Audi drive select

Audi drive select lets you adapt the driving characteristics of the A5 to suit your requirements. At the push of a button. Sportier, more comfortable, more balanced, more economical or even individually tailored as you please. It's entirely up to you.

>>> Dynamic steering

The dynamic steering enhances handling and driving comfort with speed-sensitive control of the steering ratio.

>>> Electromechanical power steering

The speed-sensitive power steering conveys a precise steering feel even at high speeds, helps you to countersteer and makes light work of parking.

>>> quattro®

The permanent all-wheel-drive system distributes the drive forces to each individual wheel according to the driving situation for extra traction and dynamic performance.

>>> quattro® with sport differential

The quattro permanent all-wheel drive with electronically controlled sport differential guarantees superb agility and thrilling driving dynamics.

Dynamics

Dynamics

that will take hold of you.

Get in. Buckle up. Start the engine. Wherever you're heading, enthralling driving dynamics will power you there. For as you know, the world is your oyster once you get behind the wheel of your Audi A5. You decide the direction. The driving style. The pace. And you enjoy the satisfaction of knowing you have plenty in reserve. More than enough to get the very best from every drive.

The fuel consumption and CO₂ emission figures as well as the efficiency classes can be found from page 90 onwards. You can find out which equipment features are available as standard or optional in your model by referring to the index starting on page 94.

Assistance systems

Wherever you're heading, peace of mind will be your constant companion.

With the assistance systems in your Audi A5.

Each drive is different. Yet they all have one thing in common – the feeling of being protected that you get from every Audi. All driver assistance systems in your Audi A5 help you during your journey and guarantee even greater comfort when you're on the road. Get to know the most important driver assistance systems.

>>> **adaptive cruise control including Audi pre sense front**
monitors the traffic in front of you, brakes or accelerates automatically to maintain distance, and warns you about vehicles early on.

>>> **Audi side assist**
monitors traffic behind the vehicle and helps you when changing lanes.

>>> **Audi active lane assist**
helps you to keep in lane by means of gentle steering intervention when lane boundary markings are detected.

>>> **Cruise control**
at speeds of around 30 km/h and above, the system keeps the set speed constant and applies the brakes automatically, e.g. when driving downhill.

>>> **Parking system plus with reversing camera**
provides a better overview for parking and manoeuvring by showing visual displays of the area behind the vehicle.

>>> Audi connect

Use all the optional services supported by Audi connect with MMI navigation plus – quickly and easily. The intuitive operation of the MMI makes accessing many internet-based functions remarkably straightforward.

>>> Navigation

With MMI navigation plus, you can let yourself be guided even more conveniently to your destinations with high-quality map views and a 3-dimensional display of places of interest and landmark buildings.

>>> Car

Control and alter driver assistance systems, vehicle settings as well as climate control and service functions quickly and easily using the MMI.

>>> Media

Browse through the covers of your music collection on all available media sources such as inserted SD cards, Audi music interface, CDs or DVDs.

>>> Phone

Make phone calls safely and easily using the hands-free facility: simply select the number to dial from your contacts in the MMI or enter the number intuitively via the MMI.



**Simplicity****The MMI® – intelligent, individual, intuitive.**

Streamlined. Simple. Logical. The world of mobile infotainment completely redefined: the Multi Media Interface (MMI). Phoning, navigating or surfing the internet via Audi connect: all highly intuitive, highly functional and highly convenient – not least thanks to voice control. With the MMI in your Audi A5, everything will be child's play for you.



As unique as you are. The equipment options.

Sportiness, comfort, design, functionality – whatever you demand of your Audi, it offers you a wealth of custom options. Audi equipment versions are varied and high-quality and you can tailor them entirely to your needs.

Character takes on many forms. Here are two of them.

What makes an Audi your Audi? Vehicle equipment entirely tailored to your needs. There are a wide range of options available to you for giving your vehicle the exact touch you have in mind. More sportiness? More elegance? Let yourself be inspired.

Audi A5 Coupé in glacier white, metallic

Cast aluminium wheels in 5-V-spoke design

Sport seats, front, in Milano leather, chestnut brown

Inlays in fine grain ash, natural brown

symphony radio

Bang & Olufsen Sound System



Audi A5 Cabriolet in cuvée silver, metallic

Cast aluminium wheels in 5-arm design

Hood in brown

Sport seats, front, in Milano leather, black

Headroom heating

Inlays in aluminium Trigon

MMI navigation plus

Bang & Olufsen Sound System



The right driving force for every personality.

No matter which Audi engine you choose, they all have high compression ratios, highly efficient combustion and outstanding efficiency. In short, they deliver more power whilst using less fuel and producing fewer emissions.



35 TFSI

TFSI®

The Audi TFSI engines offer impressive efficiency with improved performance whilst at the same time retaining their dynamism. Take, for example, the 35 TFSI (170 hp) in the Audi A5 Coupé and Audi A5 Cabriolet. Or the 50 TFSI quattro with 272 hp in the Audi A5 Coupé – in combination with S tronic, with an acceleration of 0 to 100 km/h in 5.8 seconds.

- A5 Coupé/Cabriolet 35 TFSI (170 hp)
- A5 Coupé/Cabriolet 45 TFSI (225 hp)
- A5 Coupé/Cabriolet 50 TFSI quattro (272 hp)

*Also available with quattro permanent all-wheel drive.

The fuel consumption and CO₂ emission figures as well as the efficiency classes can be found from page 90 onwards.

Remaining faithful to the sporty line: the S line packages.

The S line packages emphasise the sporty character of your Audi A5. Accentuate the dynamic body line, lend the interior even more expression or give the suspension even sportier definition for enhanced driving dynamics. And make a true athlete of your Audi.



S line exterior package

Front and rear bumpers, side radiator grilles and diffuser insert
in a striking, sporty design

Side sill trims
painted in body colour

Diffuser insert
painted in platinum grey

Door sill trims
with aluminium inlay and S line logo

S line emblem
on the front wings



S line sport package

The S line sport package includes the following equipment items:

Audi Sport cast aluminium wheels in 5-twin-spoke design
size 8.5 J x 18 with 245/40 R 18 tyres¹

S line sport suspension
with more dynamic suspension tuning and vehicle lowered by a further 10 mm compared with the dynamic suspension and the sport suspension

Door sill trims
with aluminium inlay and S line logo

S line emblem
on the front wings

Interior, dashboard and headlining
in black with contrasting stitching on seat upholstery, sport leather steering wheel, gear or selector lever gaiter and floor mats (with sprint cloth/leather and perforated Alcantara/leather)

Sport seats, front
including electric lumbar support

S line sport leather steering wheel in 3-spoke design
in black leather (steering wheel grips in perforated leather) with S line emblem

Gear or selector lever knob
in perforated black leather

Inlays
matt brushed aluminium

Optionally available:

Further 18-inch (or larger) wheels

S sport seats, front with seat upholstery in fine Nappa leather
in black with S line embossing on the front-seat backrests

Seat upholstery in sprint cloth/leather, black, perforated Alcantara/leather, black, or fine Nappa leather, black or rotor grey²
with S line embossing on the front-seat backrests. Available in further colours in combination with Audi exclusive line (without S line embossing on the front-seat backrests, steering wheel without S line emblem and not perforated, contrasting stitching according to the Audi exclusive line range)

S line multifunction sport leather steering wheel in 3-spoke design, as an option flattened at the bottom
each in black leather (steering wheel grips in perforated leather) with S line emblem; on vehicles with automatic transmission optionally with shift paddles behind the steering wheel

Inlays
piano finish, black, stainless steel mesh (centre console in piano finish, black), aluminium/Beaufort, black or fine grain birch, grey; inlays in piano finish, black, aluminium/Beaufort, black or stainless steel mesh also include an instrument cluster surround in piano finish look, black

Paint finish available in all standard/optional colours and in the special colours Misano red, pearl effect or Daytona grey, pearl effect



The fuel consumption and CO₂ emission figures as well as the efficiency classes can be found from page 90 onwards.

¹You will find specifications on the technical characteristics of tyres on page 92. ²For information on when this feature will be available, please contact your Audi partner.

The sporty equipment for even more appeal: the S line competition package.

Don't just emphasise the sporty character of your Audi – enhance it. With the S line competition package. Set dynamic highlights from the exterior to the interior. And experience perfect sportiness. Every single moment, in every detail.



S line competition*

Paint finishes in ibis white, glacier white, metallic, Misano red, pearl effect, Sepang blue, pearl effect or Daytona grey, pearl effect

Features in high-gloss black

Exterior mirror housings, radiator grille and radiator grille frame, roof frame and window slot trims, side sill trims and diffuser frame

Surround for instrument cluster in piano finish look, black

Stainless steel pedals

The S line competition package is only available in combination with the optional S line exterior package and the multifunction sport leather steering wheel in 3-spoke design; optional aluminium-look shift paddles are included behind the steering wheel on models with automatic transmission.

* For information on when this feature will be available, please contact your Audi partner.
S line competition is from quattro GmbH.



The images show the Audi A5 Coupé with S line sport package.

As unmistakable as your own standards: the Audi design selection.

The Audi design selection offers you an aesthetic pre-selection of special materials and colours for the interior. Our designers have combined inlays of fine wood or brushed aluminium with exquisite leather seats featuring attractive contrasting stitching.



Audi design selection steel grey*

The Audi design selection steel grey includes the following:

- sport seats in fine Nappa leather, steel grey with contrasting stitching and piping in moor brown
- headlining in steel grey
- dashboard in moor brown
- dashboard underside in black
- centre console in moor brown
- door trim in moor brown
- door trim inserts in fine Nappa leather, steel grey
- door armrests in fine Nappa leather, steel grey with contrasting stitching in moor brown
- carpet in steel grey
- centre armrest in fine Nappa leather, steel grey with contrasting stitching in moor brown
- floor mats in steel grey with piping in moor brown
- parcel shelf in moor brown
- inlays in fine grain birch, natural agate grey or optionally at no additional cost in matt brushed aluminium
- surround for instrument cluster in piano finish look, black



* For information on when this feature will be available, please contact your Audi partner.

Your personality. Your Audi. The Audi exclusive line.

Every Audi – custom-built for you. With the Audi exclusive line, are offering you the chance to tailor your car. Selected décors and materials are combined into a harmonious whole on the interior. So you can emphasise your own particular style with elegance.



Audi exclusive line is from quattro GmbH.

Audi exclusive line

Sport seats, front

Electric lumbar support for the front seats

Two-colour seat upholstery with piping and contrasting stitching

seat side bolsters and head restraints in black/seat centre panel and piping with stitching in a choice of cognac, alabaster white, cloudy grey (only for A5 Coupé) or crimson red (only for A5 Cabriolet); in fine Nappa leather; for A5 Cabriolet also includes heat protection for the front seats

Door trim

door trim inserts in fine Nappa leather (to match seat centre panels) and leather-covered armrests in the doors in black with contrasting stitching (to match seat centre panels)

Sport leather steering wheel in 3-spoke design

with contrasting stitching (to match seat centre panels); optional: multifunction sport leather steering wheel in 3-spoke design with or without shift paddles with contrasting stitching (to match seat centre panels)

Gear or selector lever gaiter

with contrasting stitching (to match seat centre panels)

Inlays

matt brushed aluminium; optional: piano finish, black or aluminium/Beaufort, black (including surround for instrument cluster in piano finish look, black) or walnut, dark brown

Black interior

headlining in black cloth; for A5 Cabriolet includes black attachments

Floor mats

with coloured piping (to match seat centre panels)

Audi exclusive door sill trims



Sport seats, front, with two-colour seat upholstery in cloudy grey/black with piping in fine Nappa leather and contrasting stitching to match the seat centre panels, inlays in aluminium/Beaufort, black

You have an exclusive character. So why shouldn't your Audi have one too?

That the Audi exclusive range aspires to exclusivity is already evident from its name. Selected décors and coloured leather can be combined with customised paint finishes from the large selection of Audi exclusive colours to suit your own personal preferences. So you can highlight your car's exceptional character to even better advantage. Your Audi partner and the Audi exclusive Studio of the Audi Forum Neckarsulm await your wishes.



Audi exclusive is from quattro GmbH.



Audi A5 Coupé in Audi exclusive customised paint finish Ipanema brown, metallic

Audi Sport cast aluminium wheels in 10-Y-spoke design

Audi exclusive leather upholstery and trim (package 2) in Valcona leather in alabaster white/Havana brown with contrasting stitching in orange

Audi exclusive floor mats in black with leather piping and stitching in Havana brown

Audi exclusive leather controls

Audi exclusive inlays in fine grain myrtle, nutmeg



The fuel consumption and CO₂ emission figures as well as the efficiency classes can be found from page 90 onwards.

Your Audi is painted not just once. But four times.

When you choose a paint colour, choose one that best reflects your own personality. But whichever colour you opt for, you can count on the outstanding quality of our painting process. Though no thicker than a human hair, the layer of paint on an Audi is actually made up of four different coats. So not only do you look radiant in your Audi, the car is also optimally protected from environmental influences and wear. For its entire lifetime.



Quality you can see and feel: the optional acoustic hood captivates with its high-quality covers in different colours and a hood compartment with aluminium trim surround. It can be opened and closed at speeds up to 50 km/h and its fine interior materials always ensure a pleasantly quiet ride as well as excellent heat insulation.

| Hood colours

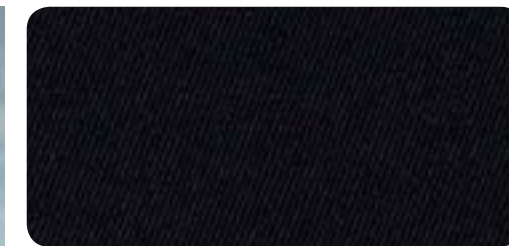

Hood, black

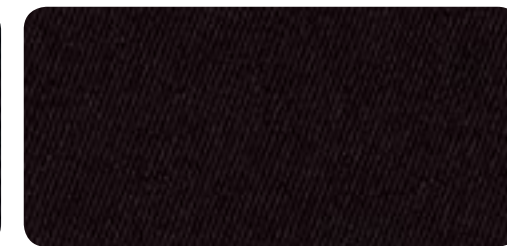

Hood, brown

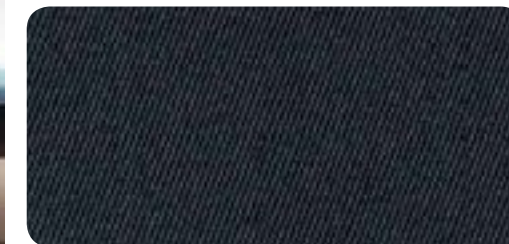

Hood, grey



Hood, red

| Solid paint finishes



Ibis white

| Metallic paint finishes



Glacier white, metallic



Tornado grey, metallic



Teak brown, metallic

| Metallic paint finishes



Utopia blue, metallic

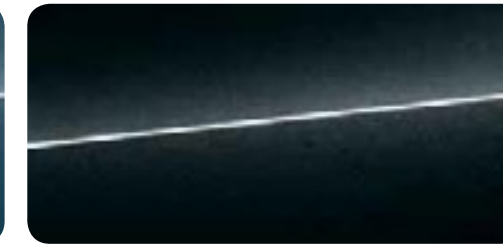

Mythos black, metallic

| Pearl effect paint finishes

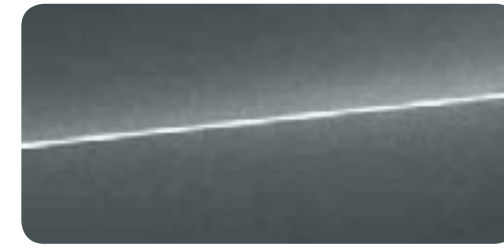

Daytona grey, pearl effect
For A5 Coupé only available in conjunction with S line sport package or S line competition, for A5 Cabriolet only available in conjunction with S line sport package



Sepang blue, pearl effect
For A5 Coupé available in conjunction with S line competition



Brilliant red



Floret silver, metallic*



Monsoon grey, metallic

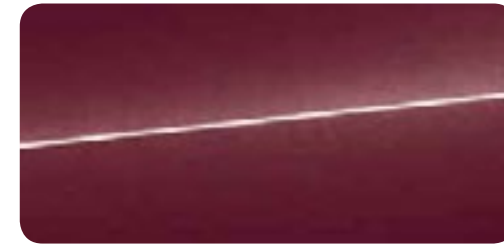

Shiraz red, metallic



Scuba blue, metallic

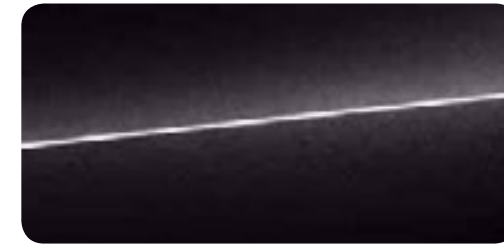

Lava grey, pearl effect



Audi exclusive customised paint finishes
From quattro GmbH

| Audi exclusive

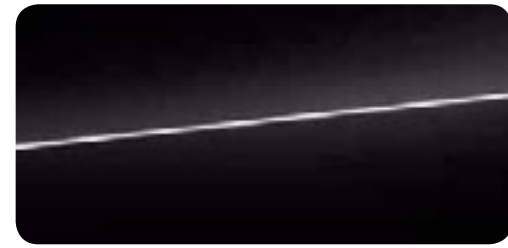

Brilliant black



Cuvée silver, metallic

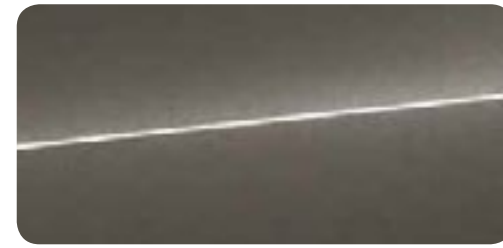

Dakota grey, metallic

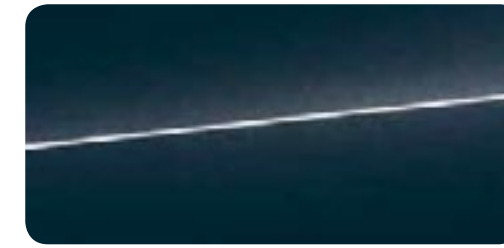

Moonlight blue, metallic



Misano red, pearl effect
For A5 Coupé only available in conjunction with S line sport package or S line competition, for A5 Cabriolet only available in conjunction with S line sport package



**Quality given form.
And a brilliant finish.
Audi wheels.**

To make sure you have peace of mind for every metre of your drive, Audi puts its wheels through an exacting series of specialised test procedures. Hardness tests, for example, aim for maximum stability, while a copper accelerated salt spray test – CASS for short – using acetic acid guarantees the greatest possible corrosion protection. Thanks to these and many other measures, we can ensure that every Audi wheel offers maximum quality – even after scores of kilometres. No matter which of the numerous designs you choose.



**The perfect connection
between an Audi and
the road.**

With a wide variety of designs and top-quality workmanship, we have a comprehensive range of wheels to put the perfect finishing touch to your Audi. Each Audi model has a tailored set of wheel options. Emphasise the character of your Audi according to your own individual wishes. Would you perhaps like to give it a more dynamic appearance? Then our special Audi Sport range of wheels is what you're looking for. Just let yourself be inspired. No matter which design you choose, it is you who determines the style.

| Summer wheels



Forged aluminium wheels in 6-arm design
size 7.5 J x 17 with 225/50 R 17 tyres¹



Cast aluminium wheels in 6-spoke parabola design
size 8 J x 17 with 245/45 R 17 tyres¹
(optionally available with run-flat tyres)



Cast aluminium wheels in 5-V-spoke design
size 8.5 x 18 with 245/40 R 18 tyres¹



Audi Sport cast aluminium wheels in 5-twin-spoke design
size 8.5 J x 18 with 245/40 R 18 tyres¹.
From quattro GmbH



Cast aluminium wheels in 5-arm Y design
size 8.5 J x 19 with 255/35 R 19 tyres¹



Audi Sport cast aluminium wheels in 5-arm rotor design in matt titanium look, gloss turned finish²
size 9 J x 19 with 255/35 R 19 tyres¹.
From quattro GmbH



Audi Sport cast aluminium wheels in 5-twin-spoke design³
size 9 J x 20 with 265/30 R 20 tyres¹.
From quattro GmbH



Forged aluminium winter wheels in 6-arm design
size 7.5 J x 17 with 225/50 R 17 tyres¹, permissible top speed 210 km/h, can be fitted with snow chains (optionally available with run-flat tyres)

| Winter wheels



Cast aluminium wheels in 5-arm design
size 7.5 J x 17 with 225/50 R 17 tyres¹



Cast aluminium wheels in 7-arm parabola design
size 7.5 J x 17 with 225/50 R 17 tyres¹



Cast aluminium wheels in 15-spoke star design
size 8.5 x 18 with 245/40 R 18 tyres¹



Audi Sport cast aluminium wheels in 10-spoke design
size 8.5 J x 18 with 245/40 R 18 tyres¹.
From quattro GmbH



Cast aluminium wheels in 10-spoke design
size 8.5 J x 19 with 255/35 R 19 tyres¹



Audi Sport cast aluminium wheels in 7-twin-spoke design
size 9 J x 19 with 255/35 R 19 tyres¹.
From quattro GmbH



Audi Sport cast aluminium wheels in 5-twin-spoke design in matt titanium look, gloss turned finish^{2,3}
size 9 J x 20 with 265/30 R 20 tyres¹.
From quattro GmbH



Cast aluminium winter wheels in 5-V-spoke design
size 8.5 J x 18 with 245/40 R 18 tyres¹, permissible top speed 240 km/h, cannot be fitted with snow chains



Cast aluminium wheels in 5-arm design, contrasting grey, partly polished²
size 7.5 J x 17 with 225/50 R 17 tyres¹



Cast aluminium wheels in 5-arm dynamic design
size 8.5 x 18 with 245/40 R 18 tyres¹



Audi Sport cast aluminium wheels in 10-spoke design
size 8.5 J x 18 with 245/40 R 18 tyres¹.
From quattro GmbH



Audi Sport cast aluminium wheels in 10-Y-spoke design
size 9 J x 19 with 255/35 R 19 tyres¹.
From quattro GmbH



Cast aluminium winter wheels in 5-parallel-spoke design (S design)
size 8 J x 18 with 245/40 R 18 tyres¹, permissible top speed 240 km/h, can be fitted with snow chains

Premium quality you can rely on.

You have a special place in your Audi. Exclusive comfort can be felt on the front and rear seats: thanks to high-quality materials and first-class workmanship. Whether you decide on standard seats with cloth or leather upholstery or you prefer sport seats, S sport seats or climate-controlled comfort seats with stable lateral support for dynamic driving: you're sitting in the right place.



Standard seats, front 1

The image shows standard seat, front, in fine Nappa leather, titanium grey.

The model-specific standard and optional equipment can be found in the index from page 94 onwards.



Sport seats, front 2

The image shows sport seat, front, in Alcantara/leather, black.



S sport seats, front 3

The image shows S sport seat, front, in fine Nappa leather, magma red/black, with contrasting stitching.



Climate-controlled comfort seats, front 4

The image on the left shows climate-controlled comfort seat, front, for A5 Coupé in perforated Milano leather, chestnut brown; the image on the right shows climate-controlled comfort seat, front, for A5 Cabriolet in perforated Milano leather, chestnut brown.

The model-specific standard and optional equipment can be found in the index from page 94 onwards.

| Seating comfort

Front seats, electrically adjustable

with electrical adjustment of the seat height, fore/aft position and seat and backrest angle; electric 4-way lumbar support; additionally electrical adjustment of the head restraint height (not for S sport seats, front)

Front seats, electrically adjustable

including memory function for the driver seat functions as for front seats, electrically adjustable; also 2 memory sets for the electrically adjustable driver seat and exterior mirrors

4-way lumbar support for the front seats

electric, with horizontal and vertical adjustment

Heat protection

A special colour pigmentation prevents the leather from being strongly heated up by sunlight. Infrared radiation is reflected. This can lower the surface temperature of the leather by up to 20 °C. Typical leather properties remain unaffected. With Milano leather and fine Nappa leather, the seat cushions and backrests of the front seats have heat protection; with Alcantara/leather combination not for seat centre panels.

Headroom heating

heats the headroom area at front, adjustable in 3 stages; vents on the front-seat backrests

Seat heating, front

heats the seat and backrest centre panels, for leather upholstery and trim and sport seats also heats the seat side bolsters; individually adjustable in several stages for driver and front-passenger side

Seat heating, front and rear

functions as for seat heating, front, also for the outer rear seats, can be adjusted separately in several stages

Centre armrest, front

adjustable angle; can be adjusted lengthways; with fold-open storage compartment and two 12V sockets in the centre console; for A5 Cabriolet one 12V socket in the centre console

| Rear seats

Rear seat backrest, folding

can be split-folded 40 : 60 (A5 Cabriolet 50 : 50) or completely; with remote backrest release in the luggage compartment

| Cloth



Arcade cloth, black

1



Arcade cloth, titanium grey

1



Atrium cloth, black

2



Atrium cloth, titanium grey

2

| Cloth/leather



Sprint cloth/leather, black

with contrasting stitching.

Only available in conjunction with S line sport package

2

| Part-leather



Part-leather, black

1

2



Part-leather, titanium grey

1

2

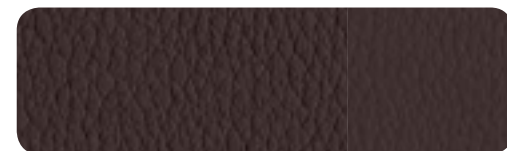

Part-leather, chestnut brown

1

2



Part-leather, velvet beige

1

| Alcantara/leather



Alcantara/leather, black

2



Perforated Alcantara/leather, black

with contrasting stitching.

Only available in conjunction with S line sport package

2



Alcantara/leather, lunar silver/black

Restricted availability

2



Alcantara/leather, titanium grey

2

| Cloth and leather upholstery and trim

Arcade cloth upholstery and trim

for standard seats, front: seat centre panels in arcade cloth and seat side bolsters, head restraints, door/side panel trim inserts and front centre armrest (if ordered) in single-colour cloth

Atrium cloth upholstery and trim

for standard seats, front: seat centre panels in arcade cloth and seat side bolsters, head restraints, door/side panel trim inserts and front centre armrest (if ordered) in single-colour cloth

Part-leather upholstery and trim

for standard seats and sport seats, front: seat centre panels of the front seats and the two outer rear seats in leather; seat side bolsters, head restraints, door trim inserts, front centre armrest (if ordered) and centre rear seat in synthetic leather

Alcantara/leather combination

provides an exclusive and sporty look for sport seats; excellent seating comfort and good seating climate thanks to fast temperature equalisation; particularly hard-wearing, easy to clean and resistant to wear and tear. The Alcantara seat centre panels provide good support, making them especially suitable for dynamic driving styles. The side bolsters made from the fine leather complete the seat.

For sport seats, front: seat centre panels and door/side panel trim inserts in Alcantara and seat side bolsters, head restraints and front centre armrest (if ordered) in leather. Includes heat protection for A5 Cabriolet

Milano leather upholstery and trim

Extremely hard-wearing and durable leather that gives a high-quality impression with its fine, grained surface. Fully penetrated with dye and tanned without the use of chromium, the leather provides outstanding surface protection thanks to the painted coat.

For standard and sport seats, front: seat centre panels, seat side bolsters, head restraints and front centre armrest (if ordered) in Milano leather. Includes heat protection for A5 Cabriolet

For climate-controlled comfort seats, front: seat centre panels of the front seats and the non-ventilated seat centre panels of the two outer rear seats in perforated Milano leather, seat side bolsters, head restraints and front centre armrest (if ordered) in Milano leather. Includes heat protection for A5 Cabriolet

Fine Nappa leather upholstery and trim

high-quality, supple leather with a balanced lacquer coat. It has air-permeable properties thanks to its natural surface, thereby contributing to a pleasant seating climate. The leather is extremely hard-wearing, durable and resistant to fading. Its fine grain underlines its exclusive character.

For standard, sport and S sport seats, front: seat centre panels, seat side bolsters, head restraints, front centre armrest (if ordered), door/side panel trim inserts and armrests in the door trims in fine Nappa leather. Includes heat protection for A5 Cabriolet

| Leather packages

Leather-covered armrests in the door trims and rear side panel trims in fine Nappa leather

Audi exclusive leather upholstery and trim (package 1) in Alcantara/Valcona leather²

for sport seats and S sport seats, front: seat centre panels and door trim inserts in Alcantara, seat side bolsters, head restraints, armrests in the door trims and front centre armrest (if ordered) in Valcona leather. Individual choice of colour for the Alcantara, the leather and the stitching from the range of Audi exclusive colours

Audi exclusive leather upholstery and trim (package 1) in Valcona leather²

seat upholstery, seat centre panels, seat side bolsters, head restraints, door trim inserts, armrests in the door trims and front centre armrest (if ordered) in Valcona leather. Individual choice of colour for the leather and the stitching from the range of Audi exclusive colours

Audi exclusive leather upholstery and trim (package 2) in Valcona leather²

leather-covered in addition to package 1: backrest covers. Individual choice of colour for the leather and the stitching from the range of Audi exclusive colours. Seat attachments matched to the colour of the leather

Audi exclusive leather upholstery and trim (package 2) in Alcantara/fine Nappa leather²

for sport seats and S sport seats, front: seat centre panels and door trim inserts in Alcantara, seat side bolsters, head restraints, front centre armrest (if ordered), backrest covers, armrests in the door trims in fine Nappa leather; includes heat protection for the seat cushions and backrests of the front seats. Individual choice of colour for the leather, the Alcantara and the stitching from the range of Audi exclusive colours. Seat attachments matched to the colour of the leather

Audi exclusive leather upholstery and trim (package 2) in fine Nappa leather²

seat centre panels, seat side bolsters, head restraints, door trim inserts and front centre armrest (if ordered), backrest covers, armrests in the door trims in fine Nappa leather; includes heat protection for the seat cushions and backrests of the front seats. Individual choice of colour for the leather and the stitching from the range of Audi exclusive colours. Seat attachments matched to the colour of the leather

| Leather



Milano leather, black 1 2



Milano leather, velvet beige 1 2



Fine Nappa leather, black 1 2 3



Fine Nappa leather, red 2



Perforated Milano leather, black 4



Perforated Milano leather, velvet beige 4



Fine Nappa leather, black with contrasting stitching. Restricted availability 3



Fine Nappa leather, magma red/black with contrasting stitching. Restricted availability 3



Milano leather, titanium grey 1 2



Fine Nappa leather, lunar silver/black with contrasting stitching. Restricted availability 3



Fine Nappa leather, chestnut brown 1 2

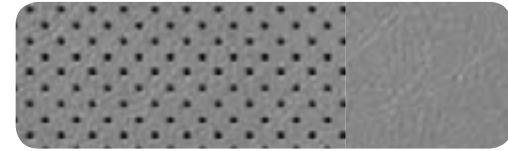

Perforated Milano leather, titanium grey 4



Fine Nappa leather, titanium grey 1 2



Fine Nappa leather, chestnut brown/black with contrasting stitching. Restricted availability 3



Perforated Milano leather, chestnut brown 4

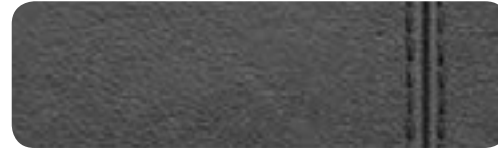

Fine Nappa leather, rotor grey¹ with contrasting stitching. Only available in conjunction with S line sport package 3



Fine Nappa leather, velvet beige 2

| Audi design selection

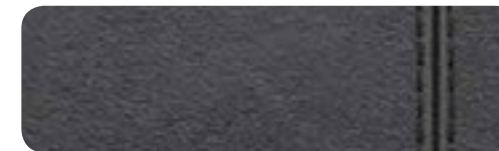

Fine Nappa leather, steel grey¹ with moor brown stitching 2

| Audi exclusive line



Fine Nappa leather, cloudy grey/black² 2

| Audi exclusive



Audi exclusive leather upholstery and trim² 1 2 3 4
Individual choice of colour for leather/stitching

| Seat variants

- 1 Standard seats, front
- 2 Sport seats, front
- 3 S sport seats, front
- 4 Comfort seats, front

¹For information on when this feature will be available, please contact your Audi partner. ²From quattro GmbH.

Experience fascination. Down to the last detail.

Exclusive ambience is a question of style. Your style. A style you can refine down to the last detail. Create tangible accents with high-quality Audi inlays. Take pleasure in smooth wood that radiates a natural warmth. Experience the fascination of open-pore wood whose exclusivity you can literally feel. Or make a personal statement with combinations of fine woods and aluminium trim – and allow your own personal taste to determine the character.



| Inlays



Reflex finish, steel grey



Matt brushed aluminium
for A5 Coupé only available in conjunction with S line sport package, Audi exclusive line or Audi design selection, for A5 Cabriolet only available in conjunction with S line sport package and Audi exclusive line



Aluminium Trigon



Stainless steel mesh
Centre console in piano finish, black. Surround for instrument cluster in piano finish look, black.
For A5 Coupé and A5 Cabriolet only available in conjunction with S line sport package



Fine grain birch, grey
for A5 Coupé and A5 Cabriolet only available in conjunction with S line sport package



Fine grain birch, natural agate grey¹
Only available in conjunction with Audi design selection



Walnut, dark brown



Fine grain ash, natural brown



Beaufort oak, light brown



Aluminium/Beaufort, black²
surround for instrument cluster in piano finish look, black



Piano finish, black²
surround for instrument cluster in piano finish look, black



Audi exclusive inlays²

Inlays
for door trims and centre console if the front centre armrest has also been ordered

Inlays in Audi exclusive wood²
available in fine grain ash, nougat; oak sepia and fine grain myrtle nutmeg

Inlays in aluminium/Beaufort, black²
Aluminium/Beaufort is produced using a sophisticated process and consists of aluminium layered with blackened wood. This unusual combination of materials unites natural elements with dynamism.

| Headlights



Headlights

uniform illumination of the road with halogen headlights using free-form technology with clear glass cover, electric headlight range control and parking light function; integrated daytime running lights

adaptive light

pivoting xenon headlights, improved lateral illumination of the course of the road thanks to dynamic cornering light (operational between speeds of approx. 10 to 110 km/h) and static turning light which is activated automatically if the indicator has been engaged for a while at low speeds and illuminates the new direction in which the vehicle is travelling

High-beam assist

improves the driver's visibility and ensures a more relaxed drive thanks to the extra comfort and convenience. Depending on the traffic situation, the high beam is automatically switched on or off. Working within system limits, it automatically detects the headlights of oncoming traffic, the rear lights of other road users and built-up areas; includes light/rain sensor

Light/rain sensor

automatic control of headlight activation, windscreen wipers and the coming home/leaving home function: delayed switching-off/automatic switching-on of rear lights and number plate lights, front fog lights and, in conjunction with xenon plus, the LED daytime running lights when parking/opening the vehicle; includes windscreen with grey strip along the top edge

Rear lights

with reversing lights in white and rear fog lights; including high-mounted third brake light and rear number plate lights in LED technology



Xenon plus including headlight cleaning system

intensive road illumination, good uniformity and range thanks to headlights with durable gas discharge technology for dipped and high beam. Automatic-dynamic headlight range control prevents oncoming traffic from being dazzled. Includes homogeneous LED daytime running light strip, LED rear lights and headlight cleaning system



LED rear lights

brake lights, tail lights, rear fog lights, indicators and rear number plate lights in LED technology with low power consumption; with reversing lights



Front fog lights

for better illumination of the road when visibility is poor; integrated neatly into the bumper

| Interior lighting

Lighting package

Anti-glare interior lighting comprising:

- reading lights, rear (for A5 Coupé)
- illuminated glove compartment
- entrance lighting, front
- active door reflectors

Plus the following in energy-saving, long-life LED technology:

- illuminated vent controls
- illuminated door handles
- footwell lighting

| Exterior design

Exhaust tailpipes

A5 Coupé:
single-branch design, 2 tailpipes on the left with chrome-plated trims, for 35 TFSI and 45 TFSI; dual-branch design, 1 tailpipe each left and right, with chrome-plated trims, for 50 TFSI

A5 Cabriolet:

dual-branch design, 1 tailpipe each left and right, with chrome-plated trims, for 35 TFSI, 45 TFSI and 50 TFSI

Aluminium-look exterior

surface of windscreen frame, window slot trims and cover strip in anodised aluminium

Gloss package

roof frame and window slot trims in anodised aluminium

Audi exclusive black gloss package*

creates black styling accents around the Audi Singleframe, the front bumper and the trim strips on the side windows. Design varies depending on model and equipment.

| Interior design

Aluminium-look interior

aluminium-look elements on the light switches, air conditioning, MMI rotary/push-button control, vents, mirror adjustment switch, window controls as well as around the gear or selector lever gaiter

Audi exclusive floor mats*

individual choice of colour for the floor mats, the leather piping and the stitching from the range of Audi exclusive colours

Audi exclusive carpet and floor mats*

Individual choice of colour for the carpet, the floor mats, the leather piping and the stitching from the range of Audi exclusive colours

Door sill trims with aluminium inlay

| Steering wheels/controls



Multifunction sport leather steering wheel in 3-spoke design

for operating the available infotainment features; adjustable for height and reach; will full-size airbag; colour-coordinated with the selected colour for the top side of dashboard. Optionally with shift paddles for changing gear manually on models with automatic transmission



Sport leather steering wheel in 3-spoke design

adjustable for height and reach, with full-size airbag; colour-coordinated with the selected colour for the top side of dashboard



Multifunction sport leather steering wheel in 3-spoke design, flattened at the bottom

features as for multifunction sport leather steering wheel in 3-spoke design; additionally flattened at the bottom

| Steering wheels/controls

Audi exclusive aluminium gear lever knob*

Audi exclusive leather steering wheel rim*

leather covering of the steering wheel rim available in all Audi exclusive colours; individual choice of colour for stitching in various Audi exclusive colours with specific Audi exclusive seam detail

Steering wheel rim with wooden segments*

for multifunction leather steering wheel in 4-spoke design, optionally with shift paddles; available in walnut, dark brown

Audi exclusive steering wheel rim with wooden segments*

for multifunction leather steering wheel in 4-spoke design, optionally with shift paddles; customised with Audi exclusive wood and leather; individual choice of colour for stitching in various Audi exclusive colours with specific Audi exclusive seam detail

Audi exclusive leather controls*

leather covering of the steering wheel rim, gear/selector lever knob and gaiter available in all Audi exclusive colours; individual choice of colour for stitching in various Audi exclusive colours; stitching on the steering wheel rim with specific Audi exclusive seam detail

| Mirrors

Exterior mirrors with integrated LED indicator

electrically adjustable, convex, flat or aspherical mirror glass. Body-coloured housing

also optionally:

heated

including heated windscreen washer jets

heated and electrically folding

including heated windscreen washer jets and automatic kerb-side function for the exterior mirror on the passenger side

heated, electrically folding and automatically dimming

including heated windscreen washer jets and automatic kerb-side function for the exterior mirror on the passenger side

heated, electrically folding and automatically dimming with memory function

including heated windscreen washer jets and automatic kerb-side function for the exterior mirror on the passenger side

The automatic kerb-side function tilts the exterior mirror on the passenger side downwards when reverse gear is selected, giving the driver a better view of the kerb.

Interior mirror

manually dimming

or optionally:

automatically dimming

with light/rain sensor and windscreen with grey strip; for A5 Coupé additionally with acoustic glazing for improved windscreen insulation and reduced noise from outside

| Roof systems



Panoramic tilt sunroof

electrically operated raising action, with tinted single-glazed safety glass and manually adjustable sun screen; convenience opening/closing from outside via the vehicle key

Hood

fully automatic hood made from insulated 3-layer fabric; hood opens in 15 seconds; can be operated at vehicle speeds up to 50 km/h

Acoustic hood

operation and design as with fully automatic hood made from insulated 3-ply fabric; interior noise levels have been further improved by optimising material thickness and binding and by increasing the insulation; available in 4 colours; including vanity mirror illumination, interior front and rear compartment light in LED technology

Wind deflector

reduces draughts in the interior; simple operating concept and easy to attach; can be stowed away in the spare wheel well in the luggage compartment provided that the space-saving spare wheel has not been ordered

| Glazing

Dark-tinted windows (privacy glazing)

dark-tinted rear window, rear door windows and rear side windows

Sunblind, electric for the rear window

| Climate control



Automatic air conditioning

electronically regulates the air temperature, flow rate and distribution; with ventilation via the defroster nozzles for the windscreen and side windows; manual recirculation mode, air intake control, sunlight-dependent control and dust and pollen filter; with humidity sensor and key-coded settings; for A5 Cabriolet, key-coded settings include facility to store 2 temperatures, one for when the hood is open, one for when it is closed

3-zone deluxe automatic air conditioning

same functions as automatic air conditioning, plus separate temperature control for driver and front passenger and for the rear compartment, adjustable temperature and air distribution settings for left and right-hand sides at front; air-conditioning controls at front with digital display, air-conditioning controls in the rear centre console for setting the temperature in the rear compartment; automatic recirculation mode by means of air quality sensor, indirect ventilation, combined/fine particulate filter and light/rain sensor

Auxiliary heating/ventilation

The auxiliary heating warms up the interior and removes ice from the windows without starting the engine. The auxiliary ventilation system supplies fresh air and reduces the temperature of the interior. With timer and separate radio-operated remote control with radio feedback

| Closing systems



Convenience key

access and drive authorisation system; the key needs only be carried with you; the engine is started and switched off via the engine start-stop button on the centre console, the vehicle is unlocked and locked from outside via sensors on all door handles; the luggage compartment lid can also be opened separated when the vehicle is locked; for A5 Cabriolet convenience closing/opening of hood via the vehicle key within an approx. 4 m radius of the vehicle

Remote control key

unlocks and locks doors, luggage compartment lid and tank flap; includes convenience closing/opening function for windows; includes glove compartment locking for A5 Cabriolet

Luggage compartment lid, automatically opening

The luggage compartment lid automatically swings open when the luggage compartment is opened via the vehicle key, the button in the driver's door, or by activating the soft-touch release on the luggage compartment lid.

Garage door opener (HomeLink)

programmable radio-operated remote control with operating buttons integrated into the front roof module; can be used to open many garage doors and exterior gates; allows control of security systems and lighting systems; code identification guidance and set-up assistance provided by the optional MMI navigation plus For further information please contact your Audi partner or visit www.eurohomelink.com.

The model-specific standard and optional equipment can be found in the index from page 94 onwards.

Anti-theft alarm

monitors doors, bonnet and luggage compartment lid; includes interior monitoring (can be deactivated), tow-away protection via a vehicle angle of inclination sensor and signal horn independent of the vehicle electrical system; with safe-locking function: prevents the doors from being opened from the inside once the vehicle has been locked with the radio remote control

Preparation for tracking system

preparation for connecting a tracking system (available from Audi Genuine Accessories) that enables a stolen vehicle to be located

| Storage/transport

Storage compartments

storage compartment with bottle holder in the door trims at front; for A5 Coupé storage compartments at rear on the side of the seat and in the side panel trim, eyewear compartment in the front roof module above the interior mirror, 2 cup holders in the centre console; for A5 Cabriolet storage compartments in the side panel trim on the left and right (only on the right if the Audi sound system or Bang & Olufsen Sound System is installed), storage nets on the front-seat backrests

Storage package

storage net on the backs of the front-seat backrests, storage compartment under the front seats (if memory function for the driver seat is fitted, only under the front-passenger seat), cup holder in the rear centre armrest, lockable glove compartment



Luggage compartment package

for flexibility and convenience when transporting items and travelling; comprises a side net on the right-hand side of the luggage compartment and a luggage compartment net for attaching to 4 lashing points in the luggage compartment; includes a 12V socket

Ski/snowboard bag

for the practical transportation of long items, e.g. up to 4 pairs of skis or 2 snowboards; can be removed and secured with a strap

Through-loading facility with removable ski/snowboard bag

for the practical transportation of long items, e.g. up to 4 pairs of skis or 2 snowboards; ski/snowboard bag can be removed and secured by a strap

Lashing points

4 in the luggage compartment, for securing luggage and other objects; for A5 Coupé attachment points for the luggage compartment net

Hood compartment, variable

with lowering hood tray which lowers automatically when the hood is opened if sufficient room is available in the luggage compartment. For loading, the hood tray can be lifted when the hood is closed.

Glove compartment

lockable

Cup holders

2, in the centre console

Cup holders integrated in the rear bench seat

for 2 cups, with cover and additional storage compartment under the front-passenger seat

Cigarette lighter and ashtrays

ashtray in the centre console, front and rear (for A5 Cabriolet only at the front), cigarette lighter integrated in the front ashtray

12V socket

in the side panel trim of the luggage compartment on the right-hand side at the rear

230V socket

for direct operation of electrical consumers such as power adapters for laptops, mobile phones, games consoles or other AC equipment; works when the ignition is switched on; located in the centre console in the rear, replaces the 12V socket

Provision for trailer towing hitch

includes fitting for the control units and reinforced engine cooling. The trailer towing hitch for retrofitting is available from Audi Genuine Accessories.

Trailer towing hitch

removable and lockable, with sphere bar and ball head made from forged steel. The 13-pin socket can be swivelled out of sight behind the bumper skirt. When removed, the trailer towing hitch can be stored in the spare wheel well. Trailer stabilisation via the Electronic Stabilisation Control (ESC)

| MMI®/navigation

Driver information system

displays a host of useful vehicle information on a 3.5-inch monochrome display in the driver's direct field of vision. Attention assist provides a warning in the driver information system and via acoustic signal if it has evaluated that the driver's attention is lapsing. The system is active between around 65 km/h and 200 km/h and can be deactivated. An integrated efficiency program provides consumption data overviews.

Driver information system with colour display

shows information from the driver information system on a high-resolution colour display with an even better overview and readability; also possible to display information from assistance systems (if ordered)

MMI® navigation

- with navigation data (DVD)¹
- 6.5-inch colour display with high-quality map display and numerous detailed display options
- dynamic route guidance with TMC (where available)
- for A5 Coupé: voice control with destination entry via spelling
- additional arrow display in the driver information system
- radio with triple tuner, phase diversity
- DVD drive (MP3 and WMA compatible), also for music CDs
- 2 SDHC card readers (up to 32 GB)
- AUX-IN connection
- 8 passive loudspeakers at the front and rear, total output 80 watts



MMI® navigation plus

- hard drive navigation²
- high-resolution 7-inch colour display with high-quality map display and topographical map colouring, 3D display of e.g. city models, choice of 3 alternative routes, split-screen route information, detailed junction map and lane recommendations, scrolling along the route
- rotary/push-button control with integrated joystick function to search on the map
- speed limit display based on navigation data
- on A5 Coupé: voice control system with whole-word address input
- dynamic route guidance with TMCpro and spoken traffic information
- additional arrow display in the driver information system with colour display
- radio with triple tuner, phase diversity
- hard drive can be used to store music (20 GB)
- DVD drive (MP3, WMA, AAC and MPEG-4-compatible) for music CDs and video DVDs
- 2 SDHC card readers (up to 32 GB)
- AUX-IN connection
- 8 passive loudspeakers at the front and rear, total output 80 watts
- use of services supported by Audi connect²

¹Navigation data are not available for all countries and regions. For more information, please contact your local Audi partner. ²Requires the optional Audi connect including car phone.

| Entertainment



chorus radio

- MMI operating concept with 6.5-inch monochrome display
- CD player
- 30 station memory with dynamic station list, FM (VHF) and AM (MW) reception range
- phase diversity and speed-dependent volume control
- 8 passive loudspeakers at the front and rear, total output 80 watts

Note: certain car menu settings cannot be made using the chorus radio.



concert radio

- as for chorus radio, but with a 6.5-inch colour display and the following additional features:
- MP3, WMA and AAC-compatible CD player and SDHC card reader (up to 32 GB) as well as an AUX-IN connection
 - TP memo function (automatic storage of traffic messages whilst driving)



symphony radio

same functions as concert radio, plus 6-disc CD changer

Digital Audio Broadcasting

in addition to the range of analogue stations, reception of digitally broadcast radio stations¹ broadcast according to DAB standards, including DAB+ and, in conjunction with MMI navigation or MMI navigation plus, also DMB audio; display of information accompanying the programme (e.g. artist and track, if provided by the respective radio station) as well as additional information in the form of a slide show (e.g. cover, weather)

Digital TV reception

reception of digitally broadcast (DVB-T), uncoded television stations¹ (MPEG-2 or MPEG-4 standard), DVB-T audio stations, teletext and Electronic Programme Guide (EPG); external AV-IN connection via adapter cable; no picture possible when the vehicle is moving

Audi music interface

Portable media players² such as Apple iPod, Apple iPhone (music functionality) as well as USB storage media and MP3 players may be connected by means of special adapter cables available from Audi Genuine Accessories. Located in the glove compartment; operation via MMI or radio controls or multifunction leather steering wheel (if ordered). In conjunction with the Audi music interface, the separate AUX-IN connection is omitted.

Adapter cable set for Audi music interface

consisting of 2 connecting cables for connection of Apple iPod/iPhone with dock connection (e.g. iPhone 4) as well as data storage devices/media players² with USB port (type A); other adapter cables are available from Audi Genuine Accessories

Adapter cable set plus for Audi music interface

same features as the adapter cable set for the Audi music interface, plus possibility of cover art display and video functions in connection with Apple iPhone and more recent Apple iPod generations² (depending on the device used).



Bang & Olufsen Sound System

captivating surround sound reproduction with 14 loudspeakers (12 loudspeakers for A5 Cabriolet), including centre speaker and subwoofer. The 10-channel amplifier has a total output of 505 watts. Reproduction of 5.1 surround sound is possible in conjunction with MMI navigation plus. Exclusive loudspeaker covers with aluminium trim and dynamic driving noise compensation

CD changer

for 6 CDs (MP3 and WMA compatible). Files with digital rights management (DRM) cannot be played. Vibration-proof location in the glove compartment

Audi sound system

impressive sound thanks to 6-channel amplifier with a total output of 180 watts and 10 loudspeakers including centre speaker and subwoofer

| Communication

Audi connect including car phone

use of Audi connect and more convenient phoning thanks to integrated car phone; the vehicle is connected to the internet by means of an integrated data module. Import of phone book entries and call list management possible.

The following services supported by Audi connect are available in your model:

Mobility & navigation

- Point-of-interest (POI) search (for A5 Coupé with voice control)
- Traffic information online
- Navigation with Google Earth™³ and Google Street View™³
- Destination entry via myAudi or Google Maps™³
- Fuel prices
- Parking information
- Country information

Communication

- Wi-Fi hotspot

Infotainment

- Weather
- Audi music stream
- News online
- City events
- Travel information

Use of the services supported by Audi connect is possible only with the optional MMI navigation plus equipment and Audi connect including car phone. You also require a SIM card with data option – in the case of car phone, a SIM card with phone and data option – or a Bluetooth-capable smartphone⁴ with remote SIM Access Profile (rSAP). The services are available only in conjunction with an existing or separate mobile phone contract and only within the range of the respective mobile phone network. Additional costs may be incurred when receiving data packets from the

internet, depending on the terms of your mobile phone contract, particularly when used abroad. Because of the high data volumes involved, a data flat rate is strongly recommended. The availability of the services supported by Audi connect varies from country to country. The Audi connect services are provided for at least one year from vehicle delivery. 24 months after vehicle delivery, the Audi connect services will be extended free of charge once for 12 months. Ask your Audi partner about a subsequent extension of the Audi connect services.

Please visit www.audi.com/connect or contact your Audi partner for more detailed information about Audi connect; contact your mobile services provider for information about contract conditions.

Bluetooth interface

enables hands-free calls to be made in the vehicle using the microphone. Bluetooth-capable mobile phones⁵ can be connected to the vehicle via the interface.

Preparation for mobile phone (Bluetooth)

connects compatible mobile phones⁵ to the external aerial to reduce SAR radiation inside the vehicle and improve reception quality; operated via concert or symphony radio, MMI navigation system or multifunction leather steering wheel (if ordered); includes hands-free facility (for A5 Coupé with voice control for telephone functions) and a preparation for a mobile-specific charger from Audi Genuine Accessories

¹ Reception depends on digital network availability. ² Please contact your Audi partner or visit www.audi.com/mp3 for information on compatible media players. ³ Google and the Google logo are registered trademarks of Google Inc.

⁴ Please contact your Audi partner or visit www.audi.com/bluetooth for information on adapters and compatible mobile phones. ⁵ Please contact your Audi partner or visit www.audi.com/bluetooth for information on compatible mobile phones.

| Communication



Handset in the front for car phone

for making private phone calls; easy writing of text messages thanks to automatic word recognition; cordless handset with colour display and integrated SIM card reader housed in the front centre armrest

Bluetooth car phone

your Bluetooth-capable mobile phone¹ can be conveniently connected to the vehicle's internal data module (provided your phone supports the SIM Access Profile); additional SIM card reader in the MMI navigation fascia, transfer or phone book entries to the vehicle and call list management. Operated via the navigation system or multifunction steering wheel (if ordered)

| Assistance systems

Hold assist²

holds the vehicle stationary for unlimited periods after stopping in traffic on normal uphill and downhill gradients. The system is activated by push-button and allows the driver to drive away smoothly.

Parking system, rear²

makes reverse parking easier by indicating acoustically how far away the vehicle is from an object detected behind it; measurement is by ultrasonic sensors integrated discreetly in the bumper; activated when reverse gear is engaged

Parking system plus²

acoustic and visual parking system for the front and rear; provides assistance when parking and manoeuvring. Information shown in the MMI display; measurement is by ultrasonic sensors integrated discreetly in the bumpers; activated when reverse gear is engaged or via the button in the centre console



Parking system plus with reversing camera²

acoustic and visual parking system for the front and rear, image of area behind the vehicle shown on the MMI display, with dynamic display modes showing the calculated path based on the steering angle; help lines and guidelines for parking into perpendicular parking spaces and identification of point at which to apply opposite lock when parallel parking; reversing camera integrated discreetly in the handle strip of the luggage compartment lid; activated when reverse gear is engaged or via the button in the centre console

Cruise control²

at speeds of 30 km/h and above, the system keeps the set speed constant, provided that engine power and engine braking effect permit it; automatic braking intervention, e.g. when driving downhill; operated via separate steering column stalk; set speed displayed in the driver information system



adaptive cruise control²

Vehicles ahead are detected with the aid of radar sensors. The distance from the vehicle ahead is kept more or less constant by braking or accelerating (control range approximately 30–200 km/h). 4 distance levels and different driving modes can be selected individually. Includes Audi pre sense front: enhanced brake assist function warns the driver of an imminent threat of collision with the vehicle in front. Can initiate partial braking if required or boost the driver's braking action if necessary. In addition, full braking action is initiated at speeds below 30 km/h if there is a danger of collision with a stationary or moving vehicle in order to reduce the speed of the collision or to avoid the collision if possible. Operated via separate steering column stalk



Audi side assist²

warns by means of an LED display on the relevant exterior mirror of any situations assessed as critical for changing lanes. Radar sensors record the vehicle approaching at the side from behind and measure the distance and the difference in speed. The lane change assistant provides support at speeds from around 30 km/h. Activated via a button in the mirror quadrant

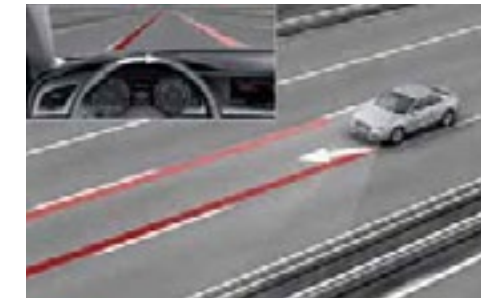

Audi active lane assist²

helps you to keep in lane by means of gentle steering intervention. The lane compliance assistant is triggered when the driver starts to cross detected lane markings without activating an indicator. The system provides assistance in the speed range from around 60 km/h to 250 km/h. Steering wheel vibration can be adjusted if the driver's wishes. Activated via a button on the indicator steering column stalk

Assistance package²

combines the following assistance systems:

- parking system plus or, on request, parking system plus with reversing camera
- adaptive cruise control
- Audi active lane assist

The systems in the assistance package complement each other and provide mutual assistance. Notes on activation and settings can be found in the description for the respective assistance system.

| Driving dynamics/brakes

Audi drive select

different modes – auto, comfort, dynamic, efficiency and (in conjunction with an MMI navigation system) individual – allow you to adjust the vehicle's characteristics by adapting the power steering assistance, accelerator and gear changing characteristics (on vehicles with automatic transmission) and the settings of other optional equipment. The efficiency mode shifts specifically selected systems to a consumption-improved basic setting.

Dynamic suspension

sporty, dynamic driving characteristics thanks to impressive driving dynamics and agile handling; 5-link lightweight front axle and trapezoidal-link rear axle with independent wheel suspension

Sport suspension

more direct contact with the road and sportier handling thanks to body being lowered by 20 mm, compared with the dynamic suspension, and stiffer spring and damper tuning

S line sport suspension

more dynamic suspension tuning and vehicle lowered by 10 mm compared with the sport suspension and the dynamic suspension

Suspension with damper control

adapts electrically to different driving situations, adjustable via Audi drive select; includes dynamic or comfort-orientated damper settings

| Driving dynamics/brakes



quattro® with sport differential.

The electronically controlled sport differential distributes variable amounts of drive force to each wheel and ensures outstanding acceleration performance in corners and stabilises the vehicle's response to load change. It also improves direct steering characteristics and provides more agile handling due to the lower steering effort required.

quattro®

permanent all-wheel drive with self-locking centre differential and asymmetric/dynamic torque distribution, as well as wheel-selective torque control and Electronic Differential Lock (EDL) on all driven wheels; distributes the drive force depending on the driving situation to each individual wheel for precisely controlled, sporty handling; quattro emblem in Audi Singleframe, on the luggage compartment lid and in the dashboard on the passenger side

multitronic®

multitronic continuously variable transmission with dynamic gear control program and sport program. Choice of 8 gears in manual mode. Includes hydraulically controlled multi-plate clutch

S tronic®

7-speed, electrohydraulically actuated dual-clutch transmission facilitates faster gear changes with virtually no break in propulsive power. In automatic mode, the driver can choose between the programs D (Drive) and S (Sport). The S tronic can be operated manually via the selector lever or the optional shift paddles behind the steering wheel. Includes hold assist

Electromechanical power steering

combines precision and comfort with exceptional energy-saving technology. The electromechanical steering system with speed-sensitive steering assistance ensures stability at high speeds whilst also being light and precise when parking and manoeuvring.

Dynamic steering

when changing lanes, parking and cornering, for example, this system improves handling and ride comfort by dynamically regulating the steering according to the driving situation; in addition to adaptation of the steering effort, the steering angle (steering ratio) is also adapted; also supports vehicle stabilisation through ESC

Brake system

dual-circuit with diagonally-split brake system, Antilock Brake System (ABS) with Electronic Brake Force Distribution (EBD), Electronic Stabilisation Control (ESC) with brake assist, tandem brake booster, disc brakes front/rear, ventilated at front

Electromechanical parking brake

includes parking brake function when stationary, drive-off assistance function through automatic release when driving away and maximum deceleration action while driving acting on all 4 wheels

| Technology/safety

Anti-Slip Regulation (ASR)

reduces spinning of the drive wheels and delivers more traction and stability on the road surface

Electronic Differential Lock (EDL)

On surfaces with varying levels of grip, this start-off assistant automatically brakes the drive wheels on any surface that is too slippery, thereby ensuring smooth, powerful progress; operates at speeds up to approx. 100 km/h.

Electronic Stabilisation Control (ESC)

provides greater stability at any speed by selective braking of individual wheels and intervention in the engine management system; networks the ABS, EBD, ASR and EDL with its own sensors and compares the driving data with reference data

Electronic Stabilisation Control (ESC)

with electronic axle-differential lock

modifies the drive forces through selective brake intervention, depending on the driving situation. When cornering, the electronic axle-differential lock ensures more precise and more neutral handling with no understeer. Improves traction and dynamic performance when cornering

Recuperation

economises on fuel through brake energy recovery; kinetic energy is converted into usable electrical energy by increasing the generator voltage when the vehicle is coasting or braking and relieving the generator during subsequent acceleration

Start-stop system

helps to reduce fuel consumption and CO₂ emissions by automatically switching off the engine when the vehicle is stationary, e.g. at traffic lights. The engine is restarted as soon as the clutch is pressed (manual transmission) or the footbrake is released (automatic transmission). May be deactivated using a switch at any time

Airbags

full-size airbags for driver and front passenger; including passenger airbag deactivation switch if ISOFIX child seat mounting for the front-passenger seat is fitted

Side airbags, front

integrated into the front seats

Side airbags, front, and head airbag system

side airbags, front integrated into the backrest; with additional head airbag system, unfolds over the entire length of the side windows and thus protects front and outer rear seats in the event of a side impact

Integrated head restraint system

increases safety and reduces the danger of whiplash. In the event of a rear-end collision, the design of the front seat better restrains the upper torso and provides stronger support for the head than conventional systems.

Active roll-over protection

protects passengers in the back by means of an automatically triggered protective system behind the rear head restraints

Seat belts

3-point inertia reel seat belts for all seats, with belt force limiters, seat belt tensioners and seat belt reminder at the front (seat belt tensioners front and rear for A5 Cabriolet); colour-coordinated with the interior

Automatic belt presenter

with 2 positions for people of different heights. The belt is automatically moved forward upon activation of the ignition and moved back again after the seat belt has been fastened.

ISOFIX child seat mounting for the rear seats

standard mounting for practical attachment of ISOFIX child seats. You can obtain the recommended child seats from your Audi partner.

ISOFIX child seat mounting and top tether for the rear seats

standard mounting for practical attachment of ISOFIX child seats; including additional attachment point (top tether)

You can obtain the recommended child seats from your Audi partner.

ISOFIX child seat mounting for the front-passenger seat

with front-passenger airbag deactivation switch

*Registered trademark of the Verband der Automobilindustrie e. V. (VDA).

Audi Genuine Accessories. As individual as the life you lead.

Whether as a Coupé or Cabriolet, the Audi A5 combines fascinating design with a thrilling driving sensation. Audi Genuine Accessories provide you with numerous ways of adding your own very personal touch to this experience. With products that keep our quality promise day in, day out. Benefit from customised solutions with convincing design and functionality. Because creativity in development and high production standards alongside numerous testing procedures are just as decisive for Audi Genuine Accessories as for the Audi vehicles themselves. Discover which tailor-made ideas Audi Genuine Accessories have ready for your lifestyle. A few highlights are illustrated here – please contact your Audi partner for more information on the complete range.



Further information can be obtained from the Audi A5 accessories catalogue, at www.audi-me.com and from your Audi partner.

Cast aluminium wheels in 15-spoke design, gloss turned finish¹, silver
Intricate drop-centre wheel in size 9 J x 19 for 255/35 R 19 tyres².



Universal mobile phone holder

Allows low-radiation phone calls through connection to the external aerial and stores the mobile phone safely while driving. The mobile phone is placed conveniently into the universal holder and wirelessly connects with the external aerial of the vehicle. Can be used for many popular mobile phone models. Thus there is no need to change adapters when you switch mobile phones. Pre-condition: preparation for mobile phone (Bluetooth). The USB charging adapters, available separately for many popular mobile phone models, enable easy charging of your mobile phone's battery.



Ski and luggage box (480 l)

Ski box for winter sports equipment and other luggage. Lockable and can be opened from both sides. Easy-to-clean thanks to smooth surface. Can only be used for the A5 Coupé and only in conjunction with the carrier unit. A ski and luggage box with 450 l volume and a compact luggage box with 370 l volume are also available.

The fuel consumption and CO₂ emission figures as well as the efficiency classes can be found from page 90 onwards.

¹Please note the special information relating to wheels on page 92. ²You will find specifications on the technical characteristics of tyres on page 92.

Premium textile floor mats (not shown)

Tailored to the dimensions of the Audi A5 floor. Made from hard-wearing, dense velour. With special coating on the underside. All floor mats are attached at the front to the points provided in the vehicle floor. With A5 logo.

Luggage compartment mat (not shown)

Lip all the way round provides the luggage compartment floor with better protection against soiling. The non-slip pattern reduces any slipping of the load. Is easily stowed and takes up little space.

Audi tracking system plus (not shown)

enables a stolen vehicle to be located and tracked via GPS/GSM technology in 27 European countries. With automatic driver recognition and intelligent restart inhibitor. For more detailed information, please contact your Audi partner.

Adapter cables for Audi music interface

enable various Apple iPod and iPhone models and other media players to be connected to the optional Audi music interface. Available in different variants. Operated via the infotainment system. For more detailed information, please contact your Audi partner.



Model	A5 Coupé 35 TFSI (170 hp)	A5 Coupé 45 TFSI quattro (225 hp)	A5 Coupé 50 TFSI quattro (272 hp)
Engine type	4-cylinder inline petrol engine with direct fuel injection, turbocharging and Audi valvelift system	4-cylinder inline petrol engine with direct fuel injection, turbocharging and Audi valvelift system	V6 petrol engine with direct fuel injection and mechanical supercharger
Displacement in cc (valves per cylinder)	1,798 (4)	1,984 (4)	2,995 (4)
Max. output ¹ in kW at rpm	125/3,800–6,200	165/4,500–6,250	200/4,780–6,500
Max. torque in Nm at rpm	320/1,400–3,700	350/1,500–4,500	400/2,150–4,780
Power transmission/wheels			
Drive type	Front-wheel drive	quattro® permanent all-wheel drive	quattro® permanent all-wheel drive
Transmission type	multitronic	7-speed S tronic	7-speed S tronic
Wheels	Forged aluminium wheels, 7.5 J x 17	Forged aluminium wheels, 7.5 J x 17	Cast aluminium wheels, 8.5 J x 18
Tyres	225/50 R 17 ²	225/50 R 17 ²	245/40 R 18 ²
Weights/capacities			
Unladen weight ³ in kg	1,530	1,615	1,725
Gross vehicle weight in kg	1,955	2,040	2,150
Permissible roof load limit/nose weight in kg	75/80	75/80	75/80
Trailer load limit ⁴ in kg			
unbraked	750	750	750
12 % gradient	1,300	1,700	1,900
8 % gradient	1,500	1,900	2,100
Fuel tank capacity, approx. in l	63 [63]	61	61
Performance/consumption⁵			
Top speed in km/h	228	250 ⁶	250 ⁶
Acceleration 0–100 km/h in s	8.2	6.4	5.8
Fuel grade	Sulphur-free super RON 95 ⁷	Sulphur-free super RON 95 ⁷	Sulphur-free super RON 95 ⁷
Fuel consumption ⁸ in l/100 km			
urban	6.9	8.5	9.9
extra-urban	5.1	5.6	6.1
combined	5.8	6.7	7.5
CO ₂ emissions ⁸ in g/km			
urban	160	197	229
extra-urban	118	131	143
combined	134	155	174
Efficiency class/emission standard	B/EU6	C/EU6	D/EU6

Explanation of ¹ to ⁸ on page 92.

Model	A5 Cabriolet 35 TFSI (170 hp)	A5 Cabriolet 45 TFSI quattro (225 hp)	A5 Cabriolet 50 TFSI quattro (272 hp)
Engine type	4-cylinder inline petrol engine with direct fuel injection, turbocharging and Audi valvelift system	4-cylinder inline petrol engine with direct fuel injection, turbocharging and Audi valvelift system	V6 petrol engine with direct fuel injection and mechanical supercharger
Displacement in cc (valves per cylinder)	1,798 (4)	1,984 (4)	2,995 (4)
Max. output ¹ in kW at rpm	125/3,800–6,200	165/4,500–6,250	200/4,780–6,500
Max. torque in Nm at rpm	320/1,400–3,700	350/1,500–4,500	400/2,150–4,780
Power transmission/wheels			
Drive type	Front-wheel drive	quattro® permanent all-wheel drive	quattro® permanent all-wheel drive
Transmission type	multitronic	7-speed S tronic	7-speed S tronic
Wheels	Forged aluminium wheels, 7.5 J x 17	Forged aluminium wheels, 7.5 J x 17	Cast aluminium wheels, 8.5 J x 18
Tyres	225/50 R 17 ²	225/50 R 17 ²	245/40 R 18 ²
Weights/capacities			
Unladen weight ³ in kg	1,730	1,810	1,925
Gross vehicle weight in kg	2,155	2,235	2,350
Permissible roof load limit/nose weight in kg	−/80	−/80	−/80
Trailer load limit ⁴ in kg			
unbraked	750	750	750
12 % gradient	1,300	1,700	1,900
8 % gradient	1,500	1,900	2,100
Fuel tank capacity, approx. in l	63	61	61
Performance/consumption⁵			
Top speed in km/h	213	240	250 ⁶
Acceleration 0–100 km/h in s	8.9	7.2	6.3
Fuel grade	Sulphur-free super RON 95 ⁷	Sulphur-free super RON 95 ⁷	Sulphur-free super RON 95 ⁷
Fuel consumption ⁸ in l/100 km			
urban	7.2	8.6	10.2
extra-urban	5.6	5.9	6.5
combined	6.2	6.9	7.8
CO ₂ emissions ⁸ in g/km			
urban	166	199	236
extra-urban	130	136	150
combined	143	159	181
Efficiency class/emission standard	B/EU6	B/EU6	C/EU6

Explanatory notes













- ¹ The figure given was calculated using the specified measuring procedure (current version of Directive 80/1269/EEC).
- ² You will find specifications on the technical characteristics of tyres in the adjacent table.
- ³ Unladen vehicle weight includes driver (68 kg), luggage (7 kg) and fuel tank 90% full, calculated in accordance with the current version of EC Directive 92/21/EEC. Optional equipment may increase the car's unladen weight and drag coefficient, whereupon the possible payload limit and the top speed will be reduced accordingly.
- ⁴ The engine's power output always decreases with increasing altitude. At 1,000 m above sea level, and for every additional 1,000 m, deduct 10% from the weight of the outfit (trailer load limit + gross weight of the towing vehicle). Figure for trailer load limit applies to factory-fitted trailer towing hitch. If using the vehicle with a trailer towing hitch for commercial purposes, a digital tachograph may be required under certain conditions.
- ⁵ A vehicle's fuel consumption and CO₂ emissions do not just depend on how efficiently the vehicle uses the fuel, but are also influenced by driving behaviour and other non-technical factors. CO₂ is the greenhouse gas primarily responsible for global warming.
- ⁶ Regulated.
- ⁷ We recommend using sulphur-free super unleaded RON 95 fuel complying with DIN EN 228. If this is not available, use sulphur-free regular unleaded RON 91 fuel complying with DIN EN 228; power output will be slightly reduced. Unleaded RON 95 fuel with a maximum ethanol content of 10% (E10) can generally be used. Fuel consumption details refer to operation with RON 95 fuel complying with 692/2008/EC.
- ⁸ The figures given were calculated using the specified measuring procedures. The figures do not refer to one individual vehicle and do not form part of any offer, but rather should be used purely for purposes of comparison between the different vehicle models.

Important note

Special information about the wheels: wheels with gloss turned finish as well as polished or partly polished aluminium wheels should not be used in wintry road conditions. For manufacturing reasons, these wheel surfaces do not have sufficient corrosion protection for such use and they can be permanently damaged by road salt or similar.

Classifications of tyre parameters

The table shows the range of fuel efficiency, wet grip and exterior noise emission classes for the different tyre sizes of the Audi A5 Coupé, A5 Cabriolet.

	Tyre size	Fuel efficiency class	Wet grip class	Exterior noise emission class
Summer tyres	225/50 R 17	F-C	C-B	73-67  - 
	245/45 R 17	F-E	C-B	72-68  - 
	245/40 R 18	F-C	B-A	72-68  - 
	255/35 R 19	F-E	C-A	73-69  - 
Winter tyres	225/50 R 17	F-E	C	71-68  - 
	245/40 R 18	F-E	E-C	72-68  - 

It is not possible to order a specific tyre. Ask your Audi partner about the range of tyres available in your country.

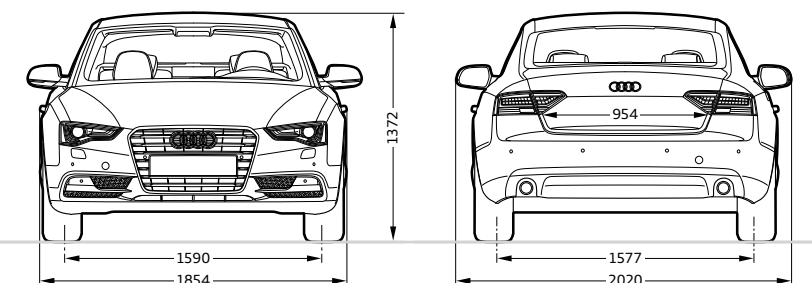
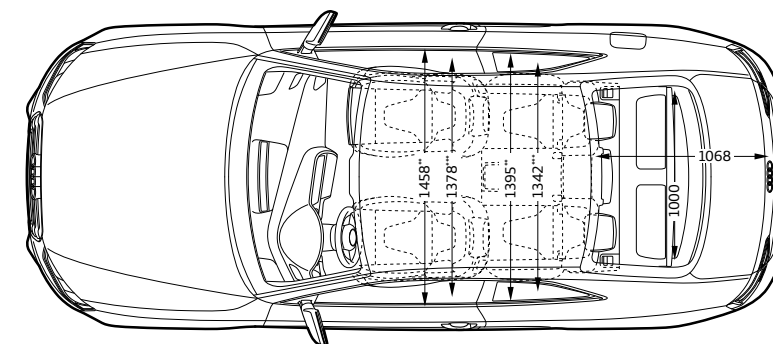
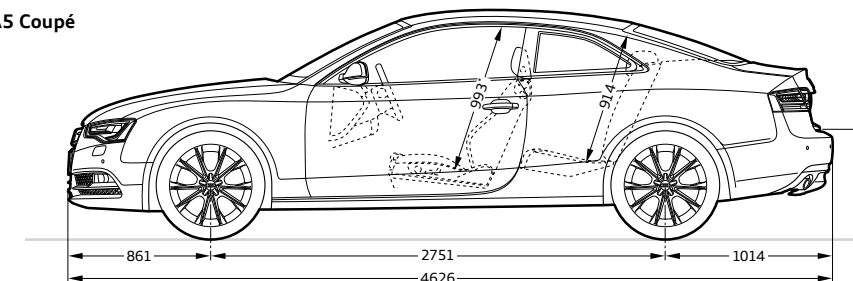
Audi A5 Coupé**Dimensions in millimetres.**

Dimensions are for unladen vehicle weight.

Luggage capacity 455/829 l (measured by the VDA method, using 200 x 100 x 50 mm blocks; 2nd value is with rear seat backrest folded down).

Turning circle approx. 11.4 m.

*Maximum headroom. **Elbow room width. ***Shoulder room width.

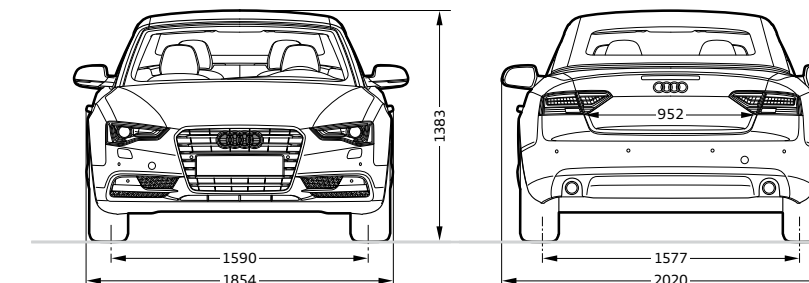
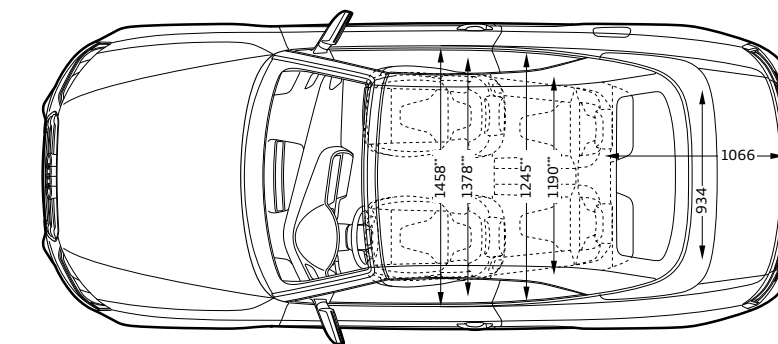
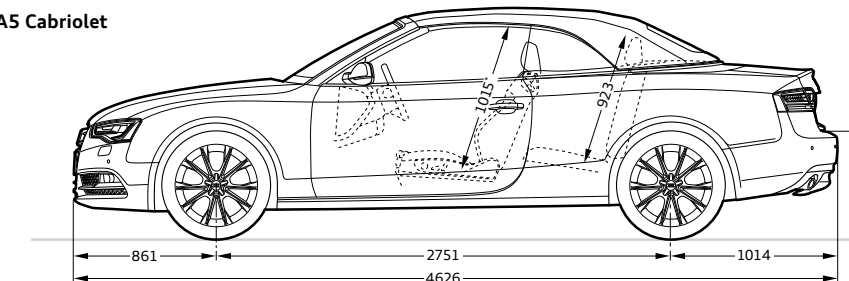









Audi A5 Cabriolet**Dimensions in millimetres.**

















Dimensions are for unladen vehicle weight.







Luggage capacity 320 l with open hood, 380 l with closed hood, 750 l with the rear seat backrest folded down (measured by the VDA method using 200 x 100 x 50 mm blocks).







Turning circle approx. 11.4 m.

*Maximum headroom. **Elbow room width. ***Shoulder room width.

	Page	A5 Coupé	A5 Cabriolet
Lines and packages	54		
S line exterior package		■	■
S line sport package		■	■
S line competition ¹		■	—
Audi design selection steel grey ¹		■	—
Audi exclusive	60		
Audi exclusive line		■	■
Audi exclusive line for S line sport package		■	■
Hood colours	64		
 Hood, black		—	□
 Hood, grey		—	■
 Hood, red		—	■
 Hood, brown		—	■
Hood lining in cloth, black (colour-coordinated with interior)			□
Hood lining in cloth, star silver (colour-coordinated with interior)		—	□
Headlining in cloth, pashmina beige (colour-coordinated with interior)		—	□
Solid paint finishes	64		
 Ibis white		□	□
 Brilliant red		□	□
 Brilliant black		□	□
Metallic paint finishes	64		
 Glacier white, metallic		■	■
 Floret silver, metallic ¹		■	■
 Cuvée silver, metallic		■	■

	Page	A5 Coupé	A5 Cabriolet
 Tornado grey, metallic		■	■
 Monsoon grey, metallic		■	■
 Dakota grey, metallic		■	■
 Teak brown, metallic		■	■
 Shiraz red, metallic		■	■
 Utopia blue, metallic		■	■
 Scuba blue, metallic		■	■
 Moonlight blue, metallic		■	■
 Mythos black, metallic		■	■
Pearl effect paint finishes	65		
 Daytona grey, pearl effect		■ ²	■ ³
 Lava grey, pearl effect		■	■
 Misano red, pearl effect		■ ²	■ ³
 Sepang blue, pearl effect		■ ⁴	—
Audi exclusive	65		
 Audi exclusive customised paint finishes		■	■
Wheels/tyres	66		
 17" forged aluminium wheels in 6-arm design		□ ⁵	□ ⁵
 17" cast aluminium wheels in 5-arm design		■ ⁵	■ ⁵

	Page	A5 Coupé	A5 Cabriolet
 17" cast aluminium wheels in 5-arm design, contrasting grey, partly polished ⁶		■	■
 17" cast aluminium wheels in 6-spoke parabola design		■ ⁵	■ ⁵
 17" cast aluminium wheels in 7-arm parabola design		■ ⁵	■ ⁵
 18" cast aluminium wheels in 5-arm dynamic design		□ ⁷	□ ⁷
 18" cast aluminium wheels in 5-V-spoke design		■	■
 18" cast aluminium wheels in 15-spoke star design		■	■
 18" Audi Sport cast aluminium wheels in 5-twin-spoke design		■	■

	Page	A5 Coupé	A5 Cabriolet
 18" Audi Sport cast aluminium wheels in 10-spoke design		■	■
 18" Audi Sport cast aluminium wheels in 10-spoke design		■	■
 19" cast aluminium wheels in 5-arm Y design		■	■
 19" cast aluminium wheels in 10-spoke design		■	■
 19" Audi Sport cast aluminium wheels in 5-arm rotor design in matt titanium look, gloss turned finish ⁶		■	■
 19" Audi Sport cast aluminium wheels in 7-twin-spoke design		■	■
 19" Audi Sport cast aluminium wheels in 10-Y-spoke design		■	■





□ Standard equipment ■ Optional equipment — not available ■ Standard/optional equipment varies by model







Country-specific variations possible. Please find out from your local Audi partner which equipment is standard and what optional equipment is available in your country.







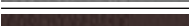

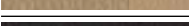
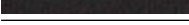
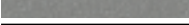

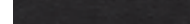





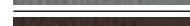
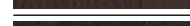
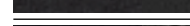
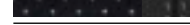

More detailed descriptions of a selection of items from the equipment range can be found on page 48 onwards.





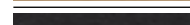
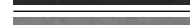
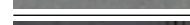

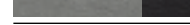



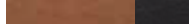

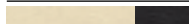
¹For information on when this feature will be available, please contact your local Audi partner. ²Only available in conjunction with S line sport package and S line competition. ³Only available in conjunction with S line sport package.

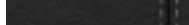
⁴Only available in conjunction with S line competition. ⁵Not available for 50 TFSI quattro (272 hp). ⁶Please note the special information relating to wheels on page 92. ⁷Standard for 50 TFSI quattro (272 hp).

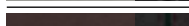
	Page	A5 Coupé	A5 Cabriolet
Wheels/tyres (continued)	66		
 20" Audi Sport cast aluminium wheels in 5-twin-spoke design ¹		■	■
 20" Audi Sport cast aluminium wheels in 5-twin-spoke design in matt titanium look, gloss turned finish ^{1,2}		■	■
 17" forged aluminium winter wheels in 6-arm design		■ ³	■ ³
 18" cast aluminium winter wheels in 5-V-spoke design		■	■
Tyre repair kit		□	□
Spare wheel, space-saving		■	■
Tyre pressure loss indicator		■	■
Anti-theft wheel bolts		■	■
Vehicle tool kit		□	□
Vehicle jack		■	■
Seats	68		
Standard seats, front		□	□
Sport seats, front		■	■

	Page	A5 Coupé	A5 Cabriolet
S sport seats, front		■ ⁴	■ ⁴
Climate-controlled comfort seats, front		■	■
Seating comfort	71		
Front seats, electrically adjustable		■	■
Front seats, electrically adjustable with memory function for driver seat		■	■
Head restraints		□	□
4-way lumbar support for the front seats		■	■
Heat protection		–	□
Headroom heating		–	■
Seat heating, front		■	■
Seat heating, front and rear		■	■
Centre armrest, front		■	■
Centre armrest, rear		□	–
Grab handles		□	–
Rear seats	71		
Rear seat backrest, folding		□	□
Seat upholstery for standard seats, front	72		
 Arcade cloth, black		□	□
 Arcade cloth, titanium grey		□	□
 Part-leather, black		■	■
 Part-leather, titanium grey		■	■
 Part-leather, chestnut brown		■	■
 Part-leather, velvet beige		■	■
 Milano leather, black		■	■
 Milano leather, titanium grey		■	■
 Milano leather, velvet beige		■	■

	Page	A5 Coupé	A5 Cabriolet
 Fine Nappa leather, black		■	–
 Fine Nappa leather, titanium grey		■	–
 Fine Nappa leather, chestnut brown		■	–
 Audi exclusive leather upholstery and trim		■ ⁵	■ ⁶
Seat upholstery for sport seats, front	72		
 Atrium cloth, black		■	–
 Atrium cloth, titanium grey		■	–
 Sprint cloth/leather, black with contrasting stitching		■ ⁴	■ ⁴
 Part-leather, black		■	■
 Part-leather, titanium grey		■	■
 Part-leather, chestnut brown		■	■
 Alcantara/leather, black		■	■
 Perforated Alcantara/leather, black with contrasting stitching		■ ⁴	■ ⁴
 Alcantara/leather, lunar silver/black		–	–
 Alcantara/leather, titanium grey		■	■
 Milano leather, black		■	■
 Milano leather, titanium grey		■	■
 Milano leather, velvet beige		■	■
 Fine Nappa leather, black		■	■
 Fine Nappa leather, titanium grey		■	■
 Fine Nappa leather, steel grey with contrasting stitching ¹		■ ⁷	–
 Fine Nappa leather, cloudy grey/black ⁸		■	■
 Fine Nappa leather, red		–	■
 Fine Nappa leather, crimson red/black ⁸		■	■
 Fine Nappa leather, chestnut brown		■	■

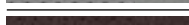
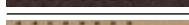
	Page	A5 Coupé	A5 Cabriolet
 Fine Nappa leather, cognac/black ⁸		■	■
 Fine Nappa leather, velvet beige		■	■
 Fine Nappa leather, alabaster white/black ⁸		■	■
 Audi exclusive leather upholstery and trim		■ ⁹	■ ¹⁰
Seat upholstery for S sport seats, front	72		
 Fine Nappa leather, black		■ ⁴	■ ⁴
 Fine Nappa leather, black with contrasting stitching		–	–
 Fine Nappa leather, rotor grey with contrasting stitching ¹		■ ⁴	–
 Fine Nappa leather, lunar silver/black with contrasting stitching		–	–
 Fine Nappa leather, chestnut brown/black with contrasting stitching		–	–
 Fine Nappa leather, magma red/black with contrasting stitching		–	–
 Audi exclusive leather upholstery and trim		■ ¹¹	■ ¹²
Seat upholstery for climate-controlled comfort seats, front	72		
 Perforated Milano leather, black		■	■
 Perforated Milano leather, titanium grey		■	■
 Perforated Milano leather, chestnut brown		■	■
 Perforated Milano leather, velvet beige		■	■
 Audi exclusive leather upholstery and trim		■ ⁵	■ ⁶
Leather packages	72		
Leather-covered door trim armrests		■	■
Audi exclusive leather upholstery and trim (package 1) in Alcantara/Valcona leather		■	–
Audi exclusive leather upholstery and trim (package 1) in Valcona leather		■	–
Audi exclusive leather upholstery and trim (package 2) in Valcona leather		■	–
Audi exclusive leather upholstery and trim (package 2) in Alcantara/fine Nappa leather		–	■
Audi exclusive leather upholstery and trim (package 2) in fine Nappa leather		–	■







□ Standard equipment ■ Optional equipment – not available ■ Standard/optional equipment varies by model

Country-specific variations possible. Please find out from your local Audi partner which equipment is standard and what optional equipment is available in your country.

More detailed descriptions of a selection of items from the equipment range can be found on page 48 onwards.

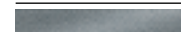
¹For information on when this feature will be available, please contact your Audi partner. ²Please note the special information relating to wheels on page 92. ³Not available for 50 TFSI quattro (272 hp). ⁴Only available in conjunction with S line sport package. ⁵Available in Valcona leather. ⁶Available in fine Nappa leather. ⁷Only available in conjunction with Audi design selection. ⁸Only available in conjunction with Audi exclusive line. ⁹Available in Valcona leather and Alcantara/Valcona leather. ¹⁰Available in fine Nappa leather and Alcantara/fine Nappa leather. ¹¹Available in Valcona leather and Alcantara/Valcona leather and only in conjunction with S line sport package.

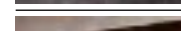
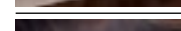
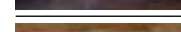
¹²Available in fine Nappa leather and Alcantara/fine Nappa leather and only in conjunction with S line sport package.

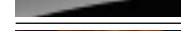
	Page	A5 Coupé	A5 Cabriolet
Headlinings			
Headlining in black cloth		■	–
Headlining in lunar silver cloth (colour-coordinated with interior)		□	–
Headlining in pashmina beige cloth (colour-coordinated with interior)		□	–
Inlays	74		
 Reflex finish, steel grey		□	□
 Matt brushed aluminium		■ ¹	■ ²
 Aluminium Trigon		■	■
 Stainless steel mesh		■ ³	■ ³
 Fine grain birch, grey		■ ³	■ ³
 Fine grain birch, natural agate grey ⁴		■ ⁵	–
 Walnut, dark brown		■	■
 Fine grain ash, natural brown		■	■
 Beaufort oak, light brown		■	■
 Aluminium/Beaufort, black		■	■
 Piano finish, black		■	■
 Audi exclusive inlays		■	■
Headlights	76		
Headlights		□	□
Xenon plus including headlight cleaning system		■	■
adaptive light		■	■
Headlight cleaning system		■	■
High-beam assist		■	■
Light/rain sensor		■	■

	Page	A5 Coupé	A5 Cabriolet
Rear lights		□	□
LED rear lights		■	■
Front fog lights		□	□
Interior lighting	76		
Interior lighting		□	□
Lighting package		■	■
Exterior design	77		
Model name/logo		□	□
Audi Singleframe		□	□
Side sill trims		■ ⁶	■ ⁶
Front bumper		□	□
Diffuser insert, rear, in platinum grey		■ ⁶	–
Rear spoiler		–	–
Exhaust tailpipes		□	□
Aluminium-look exterior		–	□
Gloss package		□	–
Audi exclusive black gloss package		■	–
Interior design	77		
Aluminium-look interior		□	□
Floor mats, front		□	□
Floor mats, front and rear		■	■
Audi exclusive floor mats		■	■
Audi exclusive carpet and floor mats		■	■
Pedals and footrest in stainless steel		–	–
Door sill trims with aluminium inlay		□	□

	Page	A5 Coupé	A5 Cabriolet
Steering wheels/controls	77		
Sport leather steering wheel in 3-spoke design		□	□
Multifunction sport leather steering wheel in 3-spoke design		■	■
Multifunction sport leather steering wheel in 3-spoke design, flattened at the bottom		■	■
Selector lever knob in leather		–	–
Audi exclusive aluminium gear lever knob		■	■
Audi exclusive steering wheel rim in leather		■	■
Steering wheel rim with wooden segments		■	■
Audi exclusive steering wheel rim with wooden segments		■	■
Audi exclusive leather controls		■	■
Mirrors	78		
Exterior mirrors with integrated LED indicator		□	□
Exterior mirrors additionally heated		■	■
Exterior mirrors additionally heated and electrically folding		■	■
Exterior mirrors additionally heated, electrically folding and automatically dimming		■	■
Exterior mirrors additionally heated, electrically folding and automatically dimming with memory function		■	■
Exterior mirror housings in aluminium look		–	–
Interior mirror, manually dimming		□	□
Interior mirror, automatically dimming		■	■
Roof systems	78		
Panoramic tilt sunroof		■	–
Hood		–	□
Acoustic hood		–	■
Wind deflector		–	■

	Page	A5 Coupé	A5 Cabriolet
Glazing	79		
Heat-insulating glass, tinted green		□	□
Dark-tinted windows (privacy glazing)		■	–
Sun visors		□	□
Sunblind, electric for the rear window		■	–
Windscreen cleaning system		□	□
Climate control	79		
Automatic air conditioning		□	□
3-zone deluxe automatic air conditioning		■	■
Auxiliary heating/ventilation		■	–
Closing systems	80		
Ignition lock		□	□
Remote control key		□	□
Electronic immobiliser		□	□
Engine start-stop button		■	■
Convenience key		■	■
Luggage compartment lid, automatically opening		□	–
Garage door opener (HomeLink)		■	■
Anti-theft alarm		■	■
Preparation for tracking system		■	■
Storage/transport	80		
Storage compartments		□	□
Storage package		■	–
Luggage compartment package		■	–
Ski/snowboard bag		–	■
Through-loading facility with removable ski/snowboard bag		■	–

□ Standard equipment ■ Optional equipment – not available ■ Standard/optional equipment varies by model

Country-specific variations possible. Please find out from your local Audi partner which equipment is standard and what optional equipment is available in your country.

More detailed descriptions of a selection of items from the equipment range can be found on page 48 onwards.

¹ Only available in conjunction with S line sport package, Audi exclusive line or Audi design selection. ² Only available in conjunction with S line sport package or Audi exclusive line. ³ Only available in conjunction with S line sport package.

⁴ For information on when this feature will be available, please contact your Audi partner. ⁵ Only available in conjunction with Audi design selection. ⁶ Only available in conjunction with S line exterior package.

	Page	A5 Coupé	A5 Cabriolet
Storage/transport (continued)	80		
Lashing points		<input type="checkbox"/>	<input type="checkbox"/>
Hood compartment, variable		–	<input type="checkbox"/>
Glove compartment, lockable		–	<input type="checkbox"/>
Cup holders		<input type="checkbox"/>	<input type="checkbox"/>
Cup holder, integrated into the rear bench seat		–	<input checked="" type="checkbox"/>
Cigarette lighter and ashtrays		<input type="checkbox"/>	<input type="checkbox"/>
12V socket		–	<input type="checkbox"/>
230V socket		<input checked="" type="checkbox"/>	–
Provision for trailer towing hitch		<input checked="" type="checkbox"/>	<input checked="" type="checkbox"/>
Trailer towing hitch		<input checked="" type="checkbox"/>	<input checked="" type="checkbox"/>
MMI®/navigation	81		
Instrument cluster		<input type="checkbox"/>	<input type="checkbox"/>
Driver information system		<input type="checkbox"/>	<input type="checkbox"/>
Driver information system with colour display		<input checked="" type="checkbox"/>	<input checked="" type="checkbox"/>
Attention assist		<input type="checkbox"/>	<input type="checkbox"/>
MMI® navigation		<input checked="" type="checkbox"/>	<input checked="" type="checkbox"/>
MMI® navigation plus		<input checked="" type="checkbox"/>	<input checked="" type="checkbox"/>
Entertainment	82		
chorus radio		<input type="checkbox"/>	<input type="checkbox"/>
concert radio		<input checked="" type="checkbox"/>	<input checked="" type="checkbox"/>
symphony radio		<input checked="" type="checkbox"/>	<input checked="" type="checkbox"/>
Digital Audio Broadcasting		<input checked="" type="checkbox"/>	<input checked="" type="checkbox"/>
Digital TV reception		<input checked="" type="checkbox"/>	<input checked="" type="checkbox"/>
Audi music interface		<input checked="" type="checkbox"/>	<input checked="" type="checkbox"/>
Adapter cable set for Audi music interface		<input checked="" type="checkbox"/>	<input checked="" type="checkbox"/>

	Page	A5 Coupé	A5 Cabriolet
Adapter cable set plus for Audi music interface		<input checked="" type="checkbox"/>	<input checked="" type="checkbox"/>
CD changer		<input checked="" type="checkbox"/>	<input checked="" type="checkbox"/>
Audi sound system		<input checked="" type="checkbox"/>	<input checked="" type="checkbox"/>
Bang & Olufsen Sound System		<input checked="" type="checkbox"/>	<input checked="" type="checkbox"/>
Communication	83		
Audi connect including car phone		<input checked="" type="checkbox"/>	<input checked="" type="checkbox"/>
Bluetooth interface		<input checked="" type="checkbox"/>	<input checked="" type="checkbox"/>
Preparation for mobile phone (Bluetooth)		<input checked="" type="checkbox"/>	<input checked="" type="checkbox"/>
Bluetooth car phone		<input checked="" type="checkbox"/>	<input checked="" type="checkbox"/>
Handset in the front for car phone		<input checked="" type="checkbox"/>	<input checked="" type="checkbox"/>
Assistance systems	84		
Hold assist		<input checked="" type="checkbox"/>	<input checked="" type="checkbox"/>
Parking system, rear		<input checked="" type="checkbox"/>	<input checked="" type="checkbox"/>
Parking system plus		<input checked="" type="checkbox"/>	<input checked="" type="checkbox"/>
Parking system plus with reversing camera		<input checked="" type="checkbox"/>	<input checked="" type="checkbox"/>
Cruise control		<input checked="" type="checkbox"/>	<input checked="" type="checkbox"/>
adaptive cruise control		<input checked="" type="checkbox"/>	<input checked="" type="checkbox"/>
Audi side assist		<input checked="" type="checkbox"/>	<input checked="" type="checkbox"/>
Audi active lane assist		<input checked="" type="checkbox"/>	<input checked="" type="checkbox"/>
Assistance package		<input checked="" type="checkbox"/>	<input checked="" type="checkbox"/>
Driving dynamics/brakes	85		
Audi drive select		<input checked="" type="checkbox"/>	<input checked="" type="checkbox"/>
Dynamic suspension		<input type="checkbox"/>	<input type="checkbox"/>
Sport suspension		<input checked="" type="checkbox"/>	<input checked="" type="checkbox"/>
S line sport suspension		<input checked="" type="checkbox"/>	<input checked="" type="checkbox"/>
S sport suspension		–	–

	Page	A5 Coupé	A5 Cabriolet
Suspension with damper control		<input checked="" type="checkbox"/>	<input checked="" type="checkbox"/>
Front-wheel drive		<input type="checkbox"/>	<input type="checkbox"/>
quattro®		<input type="checkbox"/>	<input checked="" type="checkbox"/>
quattro® with sport differential.		<input checked="" type="checkbox"/> ¹	<input checked="" type="checkbox"/> ¹
6-speed manual transmission		<input type="checkbox"/>	<input type="checkbox"/>
multitronic®		<input checked="" type="checkbox"/> ²	<input checked="" type="checkbox"/> ²
S tronic®		<input type="checkbox"/> ³	<input type="checkbox"/> ³
Electromechanical power steering		<input type="checkbox"/>	<input type="checkbox"/>
Dynamic steering		<input checked="" type="checkbox"/>	<input checked="" type="checkbox"/>
Brake system		<input type="checkbox"/>	<input type="checkbox"/>
Brake callipers, painted black		–	–
Electromechanical parking brake		<input type="checkbox"/>	<input type="checkbox"/>
Technology/safety	86		
Antilock Brake System (ABS) with Electronic Brake Force Distribution (EBD)		<input type="checkbox"/>	<input type="checkbox"/>
Anti-Slip Regulation (ASR)		<input type="checkbox"/>	<input type="checkbox"/>
Electronic Differential Lock (EDL)		<input type="checkbox"/>	<input type="checkbox"/>
Electronic Stabilisation Control (ESC)		<input type="checkbox"/>	<input type="checkbox"/>
Electronic Stabilisation Control (ESC) with electronic axle-differential lock		<input type="checkbox"/> ²	<input type="checkbox"/> ²
Recuperation		<input type="checkbox"/>	<input type="checkbox"/>
Start-stop system		<input type="checkbox"/>	<input type="checkbox"/>
Airbags		<input type="checkbox"/>	<input type="checkbox"/>
Side airbags, front		–	<input type="checkbox"/>
Side airbags, front, and head airbag system		<input type="checkbox"/>	–
Integrated head restraint system		<input type="checkbox"/>	<input type="checkbox"/>
Active roll-over protection		–	<input type="checkbox"/>

	Page	A5 Coupé	A5 Cabriolet
Safety steering column		<input type="checkbox"/>	<input type="checkbox"/>
Seat belts		<input type="checkbox"/>	<input type="checkbox"/>
Automatic belt presenter		–	<input type="checkbox"/>
ISOFIX child seat mounting for the rear seats		–	<input type="checkbox"/>
ISOFIX child seat mounting and top tether for the rear seats		<input type="checkbox"/>	–
ISOFIX child seat mounting for the front-passenger seat		<input checked="" type="checkbox"/>	<input checked="" type="checkbox"/>
First-aid kit		<input checked="" type="checkbox"/>	<input checked="" type="checkbox"/>
Warning triangle		<input checked="" type="checkbox"/>	<input checked="" type="checkbox"/>

Equipment for the Audi A5 Coupé illustrated (p. 4–19):
 Paint finish: floret silver, metallic⁶
 Wheels: cast aluminium wheels in 10-spoke design
 Seats/seat upholstery: sport seats, front, in fine Nappa leather, titanium grey
 Inlays: aluminium Trigon

Equipment for the Audi A5 Cabriolet illustrated (p. 20–31):
 Paint finish: teak brown, metallic
 Wheels: cast aluminium wheels in 5-V-spoke design
 Seats/seat upholstery: climate-controlled comfort seats, front, in perforated Milano leather, velvet beige with moor brown interior equipment
 Inlays: fine grain ash, natural brown

Standard equipment Optional equipment – not available Standard/optional equipment varies by model

Country-specific variations possible. Please find out from your local Audi partner which equipment is standard and what optional equipment is available in your country.

More detailed descriptions of a selection of items from the equipment range can be found on page 48 onwards.

¹ Only available for 50 TFSI quattro (272 hp). ² Only available for models with front-wheel drive. ³ Only available for models with quattro permanent all-wheel drive. ⁴ NA. ⁵ Restricted.

⁶ For information on when this feature will be available, please contact your Audi partner.



Discover



The Audi experience

The fascination of Audi can be experienced in many different ways. Audi City in London, for example, gives you digital access to all models at their actual size and in real time. And of course it is always worth visiting one of the major motor shows. This is where Audi always presents its new models and invites you to take a look at how the future is being shaped with "Vorsprung durch Technik". Anyone interested in seeing how Audi is already putting this into practice will find fascinating insight in the "Vorsprung durch Technik" online special at www.audi.com. But a look back can also be rewarding: at the Audi museum mobile in Ingolstadt, history and high-tech go hand in hand. A total of 130 historic exhibits and state-of-the-art forms

of presentation make for a thrilling symbiosis. Plus, Audi driving experience allows you to live the excitement and countless possibilities of current Audi models. Here, pure driving enjoyment is combined with valuable learning effects. This is ensured by a team of specially trained and highly qualified instructors who provide practical tips to help you optimise your driving skills. All this can now also be enjoyed at the recently opened Audi driving experience center in Neuburg, near Ingolstadt. Facilities here include a circuit of up to 3.4 kilometres that features challenging combinations of bends, a 30,000 m² dynamic driving area and an offroad section where Q models can be put through their paces.

